

4.16 WOODWORK (444)

4.16.1 Woodwork Paper 1 (444/1)

1. Features common to all saws

- Size is determined by length and function of blade
- Cut by taking out small pieces in the form of dust
- Fineness/coarseness of cut determined by number of points
- All have teeth i.e. projections ending in a thin top
- The teeth have to be sharpened and shaped periodically to be efficient
- Handles made of wood or plastic
- Blade is made of high carbon steel

Any 4 x 1 = 4 marks

2. Differentiation of wood carving and wood turning.

- Wood carving is the art of shaping wood using hand tools
- Wood turning is the art of shaping wood using machines

(2 marks)

3. Safety precautions when

(i) Carrying hand tools

- Do not carry many tools at once
- Do not carry sharp edged or pointed tools in your pocket
- When carrying sharp edged or pointed tools, hold them close to the body and pointed down to floor
- When passing sharp edged tools to a fellow worker pass the handle first.

Any 2 x 1 = 2 marks

(ii) When storing

- Return the tool to their correct places after use
- Always wipe free of grease or dirt after use
- Sharp point to face inside cabinet or downwards when hung on shelves

Any 2 x 1 = 2 marks

4. Effects of using unseasoned timber

- Strength properties will be reduced
- Fungal attack is more likely
- There is excessive weight due to the amount of water present
- The surface finish is unsuitable to receive either paint or polish
- Adhesives will have minimal holding properties
- Corrosive properties increases
- Timber will shrink when drying
- The wood is unworkable by hand tools

Any 4 x 1 = 4 marks

5. (a) Functions of roots

- anchor the tree to the ground
- extract water and minerals from the ground

2 x 1 = 2 marks

(b) Functions of the trunk

- produces timber
- acts as passage of water and minerals from the roots to the leaves
- supports the crown
- stores food

Any 2 x 1 = 2 marks

6. Pictorial sketches of Double and Twin Tenon

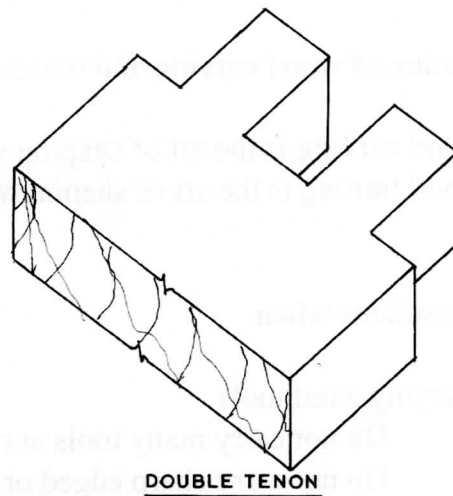
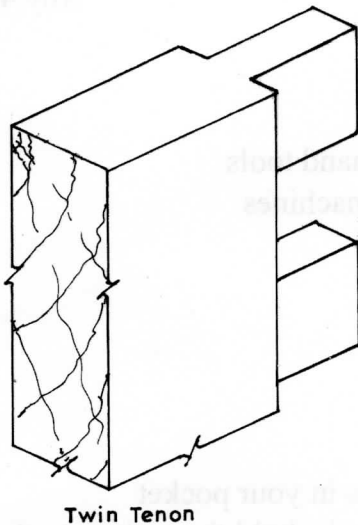

Correct tenon
Pictorial sketch

1
1

2 marks x 2 = 4 marks

7. (a) Advantages of using a roller when painting

- It is faster to paint
- It covers a wider area
- It is ideal for wide boards

(b) Sketch of veneer hammer

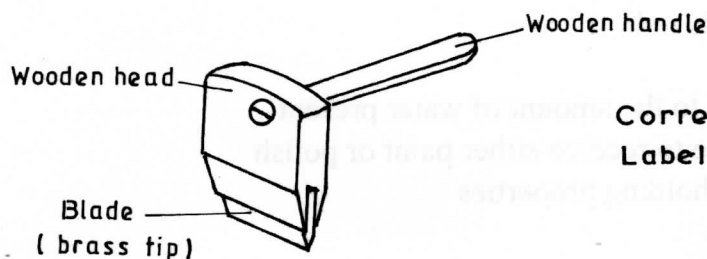

Correct sketch = 2

Labels Any 2 x 1/2 = 1

Total = 3 mks

8. To avoid splitting of wood when boring

Method 1

- Bore until the screw tip shows on the back side of the workpiece
- Remove bit and bore from the other side

Method 2

- Clamp the work piece with a backing of a waste piece
- Bore the hole till bit depth is greater than work piece thickness

2 x 2 = 4 marks

9. (a) Precautions required for steel tape

- Before starting work check its accuracy with a vernier calliper or new steel rule to ensure the hook at the end is not bent/loose
- Do not pull or push the tape when the locking device is engaged.
- Do not extend the tape beyond its limit
- Do not drop the tape measure

Any 2 x 1 = 2 marks

(b) Factors influencing choice of a finish

- appearance
- protection
- durability
- ease of application
- safety
- reversibility
- hygiene

Any 4 x $\frac{1}{2}$ = 2 marks

10. Reduction of scale

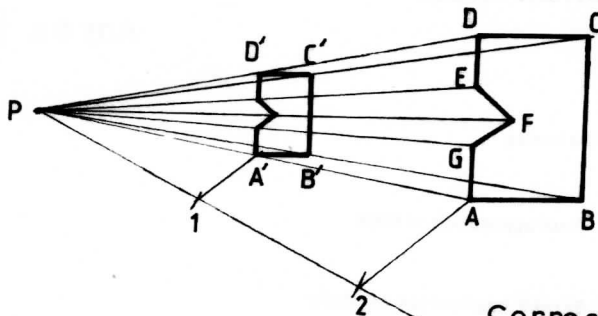

Correct focus	= 1
Correct ratio	= 1
Radiating lines	= 1
Correct reduced figure	= 1
Dimensions: A' B' - 15mm	= $\frac{1}{2}$
B' C' - 22.5mm	= $\frac{1}{2}$
Total	= 5 mks

- (b) Use of a test strip
- Make a test strip using a scrap of the same wood as that to be stained
 - Paint the test strip with one coat of stain and allow to dry
 - Paint the strip with a second coat but leave a small section of the first coat exposed for comparison
 - If required, make three or four coats and leave them to dry thoroughly.
 - Apply a band of clear finish along one half of the test strip to see how it affects each coat of stain

- (c) Types of spokeshave
- Flat spokeshave
It has a flat sole and straight iron
It is designed for planing in either a straight line or on a convex surface
 - Round spokeshave
It has a round sole and concave iron
It is designed to cut concave curves in timber

Name 2 x $\frac{1}{2}$ = 1
Description 2 x 1 = 2
3 marks)

13. (a) Cutting action of cross-cut saw teeth
- When cutting across the grain the teeth of the saw must be shaped in a manner that they can sever the fibres on each side of the saw kerf. For this to happen, adjacent teeth are brought to points on opposite sides of the blade.

The points and knife-like edges on the teeth cut the fibres forming a kerf.
The teeth are set to provide clearance for the blade in the kerf
The front of the teeth are inclined at about 70° - 80° so that they do not burry themselves in the fibre.

Any 6 x 1 = 6 marks

- (b) Methods of matching veneers

- (i) Book matching
A book match uses successive leaves of veneer
Every other leaf is turned over like the pages of a book, and edge-joined in this manner.
The reverse side of one leaf is the mirror image of the succeeding leaf.
The result is a series of pairs

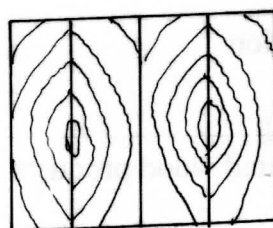

Book matching

(ii) Slip matching

This match is used to create a wide veneer from narrow ones
Consecutive veneers are slipped sideways and edge-joined together without altering their grain direction.

This provides pattern repetition.

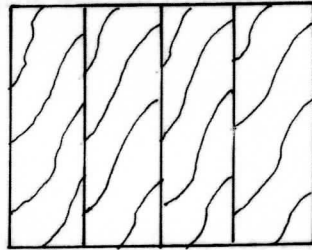

Slip matching

(iii) Diamond matching

The sheets are cut at an angle and quarter-matched to produce a diamond figure.
The sheets are matched with a common centre, joined side by side

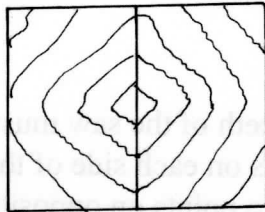

Sketches	=	3
Explanation, 3 x 2	=	3
<u>Total</u>	=	<u>9 marks</u>

14. (a) (i) Tool is a ratchet brace (1)

(iii) Functions

- W - Knob - used to apply pressure using the palm (1)
- X - Bearing - to facilitate easy movement of the handle in use (1)
- Y - Chuck - Houses the jaws and provides adjustment of jaws (1)
- Z - Jaw - provides grip to the shank of drill bits (1)

Name of tool	=	1 mark
Naming 4 parts @1	=	4 marks
Functions of the 4 parts @ 1	=	<u>4 marks</u>
		9 marks

(b) Areas of study in woodwork

- Engineering
- Furniture design and production
- Wood science
- Pulp and paper manufacturing
- Production of timber and related wood products
- Forestry

Accept any other related area

Any 4 x 1 = 4 marks

(c) Mistakes to avoid when giving first aid treatment for single burns

- Do not apply grease, ointment or medication to the burn
- Do not remove any clothing that sticks to a burn
- Do not break blisters
- Do not use dry cotton or material with loose fibre to cover the burn
- Do not touch the burned area

Any 4 x 1 = 4 marks

15.

(a) (A)

Mitre Bridle Joint

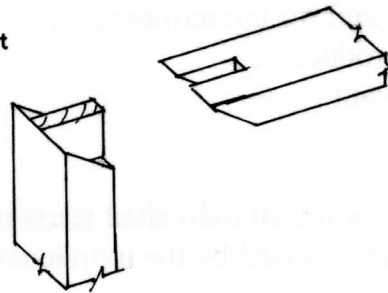

(B)

Mitre Halving Joint

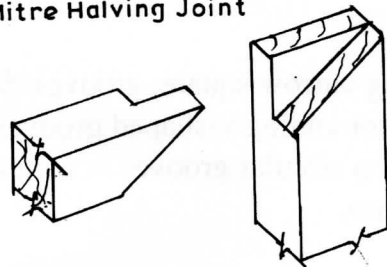

2 x 2 = 4 mks

(b) Procedure of making decorative patterns

(i) Banding

- Mark the edge of the banding using a marking gauge
- Cut the groove using a router and chisel
- mitre the ends of the banding strip
- Apply glue and press into place with a cross pein hammer

4 marks

(ii) Solid timber inlay

- Glue strips of alternate coloured timber together
- Cut the glued board across the grain to produce strips of the required size/length
- Mark centre lines on the solid timber background
- Position the inlay on the surface and cut round it with a marking knife
- Using chisels and gouges, cut the waste from the edges of the recess
- Remove the remaining waste with a finely set router plane
- Glue the inlay into place and clamp it with a block of wood

7 marks