

### 3.4 BUILDING CONSTRUCTION (446)

The 2014 KCSE examination for Building Construction consisted of two papers namely Paper 1 (theory) and Paper 2 (Practical Project). The theory was worth 60% while practical was worth 40% of the final mark. The format and weighting of the two papers was the same as in the previous years.

#### Candidates General Performance

Table 12: Candidates' overall performance for the period 2009 to 2014

Year	Paper	Candidature	Maximum Score	Mean Score	Standard Deviation
2009	1		60	31.13	6.96
	2		40	18.77	4.57
	<b>Overall</b>	<b>195</b>	<b>100</b>	<b>49.74</b>	<b>9.38</b>
2010	1		60	26.26	9.09
	2		40	17.53	3.38
	<b>Overall</b>	<b>225</b>	<b>100</b>	<b>43.79</b>	<b>13.32</b>
2011	1		60	23.72	9.09
	2		40	15.76	4.32
	<b>Overall</b>	<b>301</b>	<b>100</b>	<b>37.70</b>	<b>12.58</b>
2012	1		60	25.27	9.79
	2	376	40	16.90	4.86
	<b>Overall</b>		<b>100</b>	<b>42.13</b>	<b>13.64</b>
2013	1		60	33.75	11.52
	2	330	40	22.54	5.85
	<b>Overall</b>		<b>100</b>	<b>56.29</b>	<b>16.39</b>
2014	1		60	32.31	9.25
	2	191	40	21.68	3.92
	<b>Overall</b>		<b>100</b>	<b>53.99</b>	<b>12.20</b>

From the above table, the following observations can be made.

- (i) There was a drop in the mean score from 56.29 in the year 2013 to 53.99 in the year 2014.
- (ii) The standard deviation also dropped from 16.39 in the year 2013 to 12.20 in the year 2014.
- (iii) The candidature dropped drastically from 330 in the year 2013 to 191 in the year 2014.

#### 3.4.1 Building Construction paper 1 (446/1)

The questions which were reported to have been poorly responded to have been analyzed with a view to pointing out candidates' weaknesses and propose suggestions on some remedial measures that need to be taken into consideration in order to improve performance in future. The questions for discussions include 5a, 5b, 7a, 11, 12 b and 13.

### Question 5a

Give **four** requirements of a drainage system.

(4 marks)

#### Weaknesses

Most of the candidates could not differentiate between sub soil drainage and underground drainage.

#### Advice to Teachers

They should cover the syllabus in totality and explain to the students the difference between subsoil drainage and underground drainage system.

#### Expected Responses

- Should be self cleansing.
- Should be straight as possible between two points.
- Pipes used should be strong enough to resist the pressures placed on them.
- The bore should be laid true and smooth to ensure that water flows freely.
- Gradient should be correctly set such that water velocity is maintained which ensures solid matter will be floated along the pipe.
- Should operate without maintenance.

### Question 5b

State the function of a goose neck bend in a cold water service layout.

(1 mark)

#### Weaknesses

Most of the candidates could not state the functions of a goose neck in the cold water system.

#### Advice to Teachers

They should cover the syllabus in totality and teach the technical terms in the drainage system.

#### Expected Responses

It is used to relieve pressure likely to be exerted on the mains connection.

### Question 7a

List **two** requirements for a safety helmet to be worn on a construction site.

(2 marks)

#### Weaknesses

Most of the candidates gave reasons for using a helmet instead of the requirements as in the question.

#### Advice to Teachers

They should teach the students the requirements of safety wear.

### Expected Responses

- (i) should be hard, not to break easily.
- (ii) should have soft inner padding.
- (iii) should have strapping.

### Question 11

Figure 4 shows a pictorial drawing of a shaped block.

(15 marks)

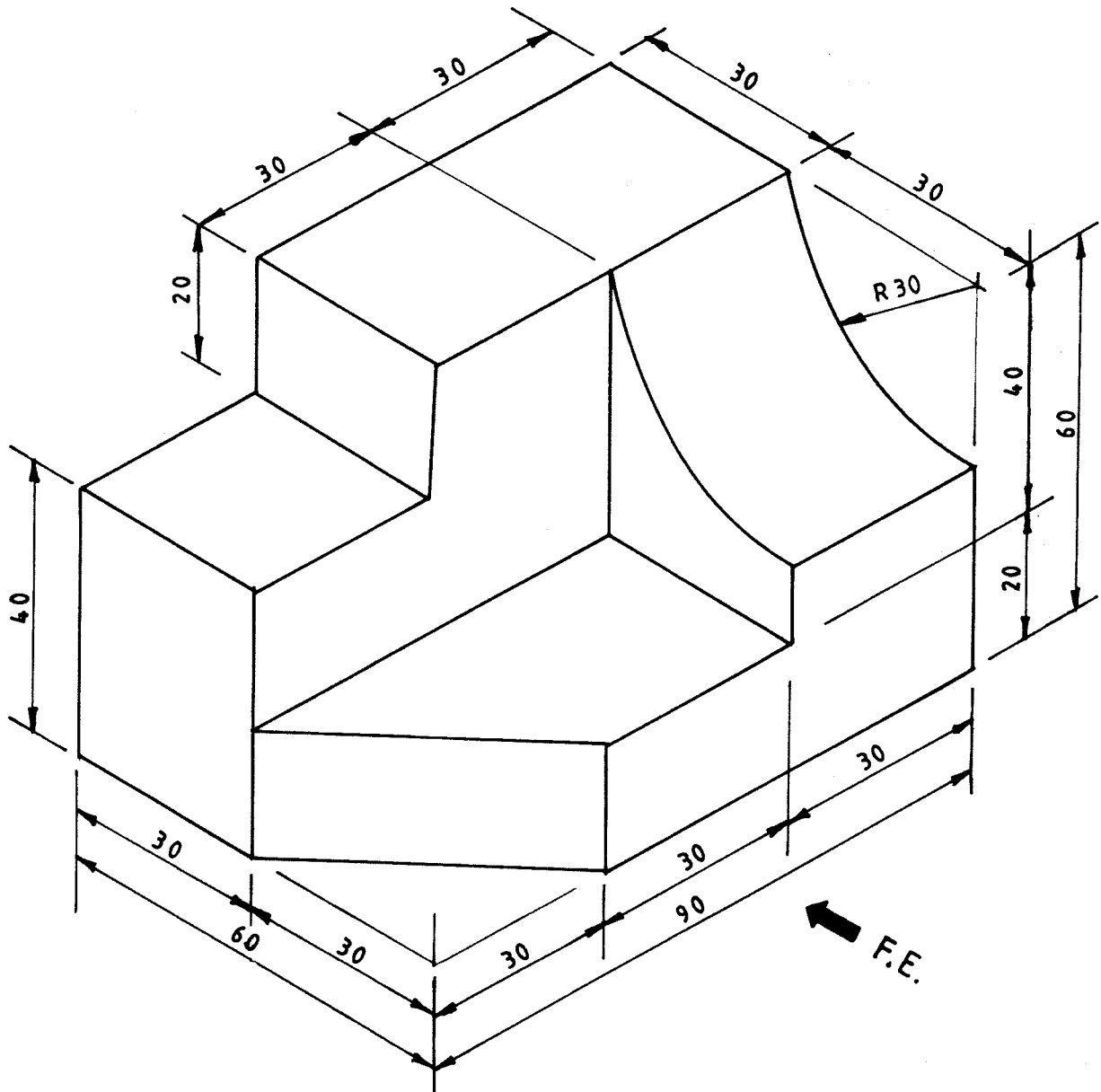

Fig. 4

To a scale of 1:1, draw **three** orthographic views of the block in 3<sup>rd</sup> angle projection. Insert **six** dimensions. (15 marks)

## Weaknesses

Most candidates could not draw the views as asked for in the question in third angle projection.

## Advice to teachers

Teachers are advised to cover the topic on orthographic projection thoroughly and explain the students the difference between first angle and third angle projection.

## Expected Responses

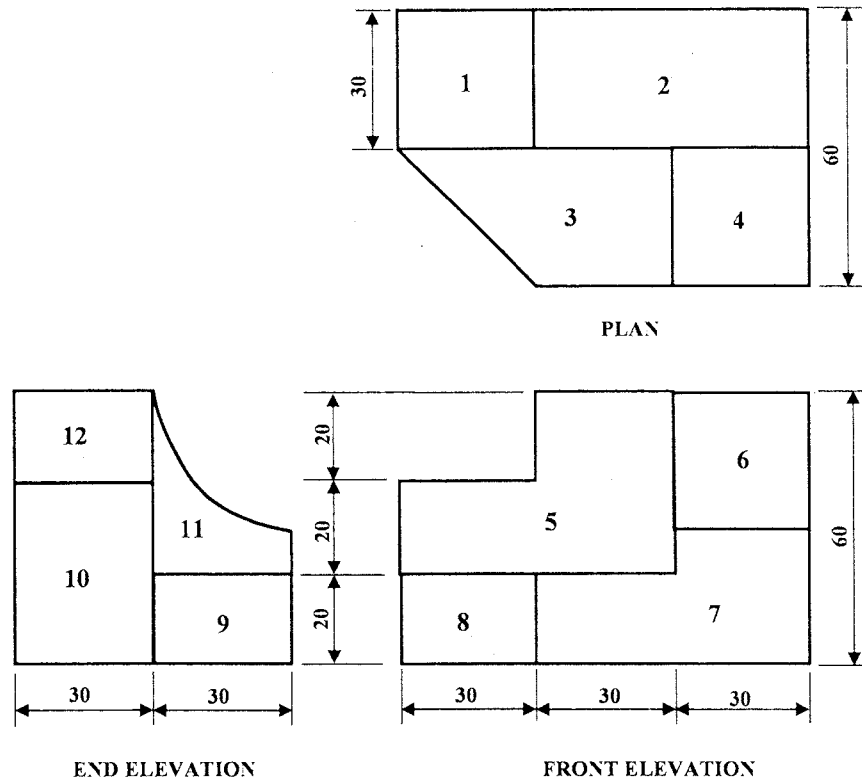

**Question 12b**

**Figure 5** shows a floor plan of a house.

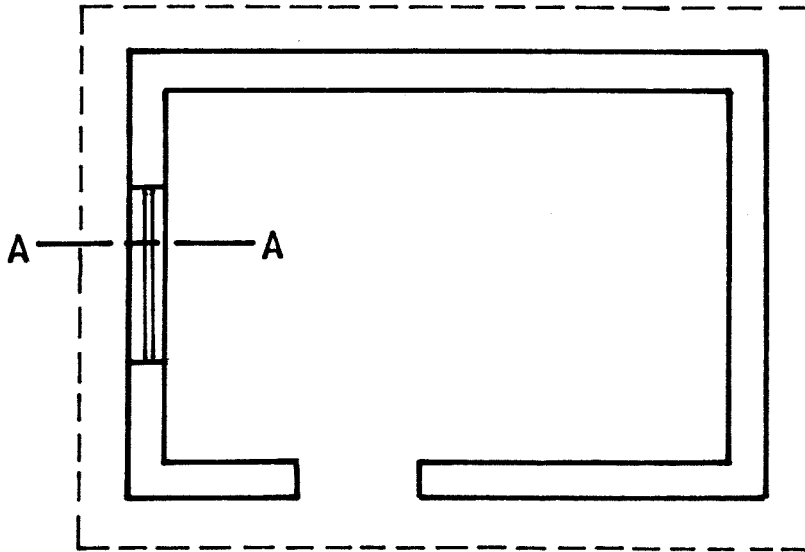

**Fig. 5**

Sketch and label a vertical section through A - A to show details from the foundation to the roof. (10 marks)

**Weaknesses**

Most candidates could not draw the vertical sketch to show the details from the foundation to the roof.

**Advice to teachers**

Teachers are advised to teach the topic of vertical sections thoroughly and give sketches to show details involved.

## Expected Responses

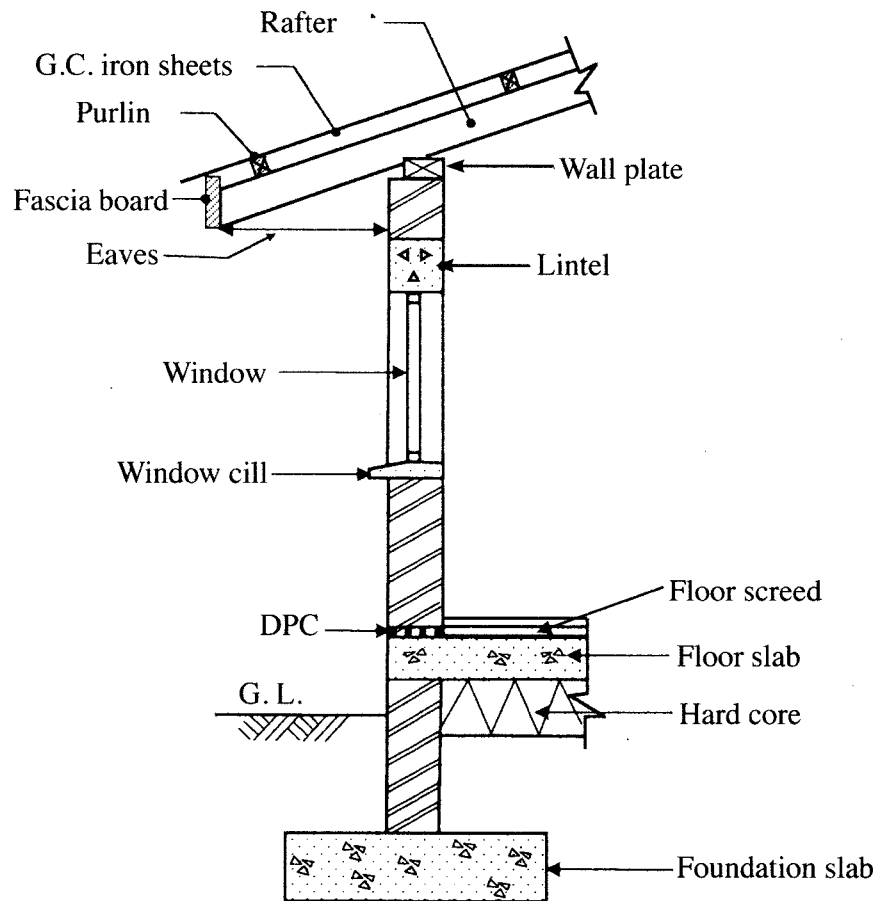

### Question 13

- (a) (i) Give **one** advantage of twisted reinforcement bars over the round reinforcement bars when used in concrete.
- (ii) State the meaning of each of the items labelled A - F in the reinforcement code given:

8	Y	20	- 01 -	300 -	B
↑	↑	↑	↑	↑	↑
A	B	C	D	E	F

(7 marks)

- (b) Explain the function of each of the following in relation to plumbing works:
- (i) cold water cistern;
  - (ii) water cylinder;
  - (iii) boiler;
  - (iv) rising main.

### Weaknesses

Most candidates did not answer this question.

### Advice to teachers

Teachers are advised to cover the topic on reinforced concrete in totality and if possible take students to construction sites to understand more on reinforcement.

### Expected Responses

(a) (i) Advantages of twisted bars over round bars.

- Twisted bars provides better grip due to increased surface area and also increases friction.
- Higher strength.

(ii) 8 Y 20 – 01 – 300 B

↑ ↑ ↑    ↑    ↑    ↑  
A B C    D    E    F

A - Number of bars.

B - Type of bar/shape of bar.

C - Bar diameter.

D - Bar mark diameter.

E - Pitch of bars (centre to centre spacing).

F - Position of bars (bottom)

(b) Functions of the following:

(i) Cold water cistern

- Receives water from the water supply/rising main.
- Stores water for use in other water points.
- Supplies the water heater.

(ii) Water cylinder

- Stores hot water for use in the house.

(iii) Boiler

- Can either be manual or electrical and is used for heating water.

(iv) Rising mains

- Connects the meter to the overhead storage tank and the kitchen valve.

### 3.4.2 Building Construction Paper 2 (446/2)

As in the previous years, the council designed a suitable project for this level together with a comprehensive marking scheme. The subject teacher used the working drawings to supervise the fabrication of the project and the marking scheme to mark the candidates' projects. The marks were then sent to the council through the D.E.Os office.