

3.20 ELECTRICITY (448)

3.20.1 Electricity Paper 1 (448/1)

SECTION A (48 marks)

Answer **all** the questions in this section.

- 1 (a) List the **three** classes of materials according to their electrical conductivity and for each class give **one** example. (3 marks)
- (b) State the meaning of the term career. (1 mark)
- 2 (a) List **four** characteristics of an entrepreneur. (2 marks)
- (b) For each of the following activities, state **one** safety precaution to be taken when: (2 marks)
- (i) removing a $470\ \mu\text{F}/240\text{V}$ capacitor from a television set circuit during repair;
- (ii) handling rotating parts of electrical machines.
- 3 With the aid of graphical symbols, describe the difference between a potentiometer and a Rheostat. (5 marks)
- 4 The average daily power consumption of a domestic consumer is as follows:
- Lighting 0.5kw for 6 hours
 - Water heating 3.0kw for 2 hours
 - Cooking 5.0kw for 2 hours
 - Other appliances 3.5kw for 3 hours
- (a) Determine the daily consumption in kWh. (3 marks)
- (b) If the monthly standing charge is Ksh.100.00, calculate the bill for a month of 30 days. (3 marks)
- 5 (a) State **four** factors that determine the strength of an electromagnet. (2 marks)
- (b) **Figure 1**, shows the direction of force on a current carrying conductor in a magnetic field. Sketch the magnetic flux lines to create the force. (2 marks)

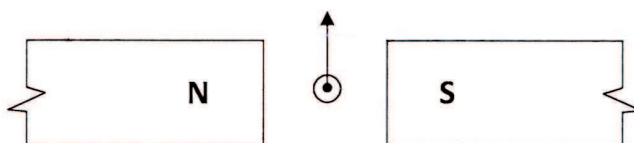

Figure 1

6

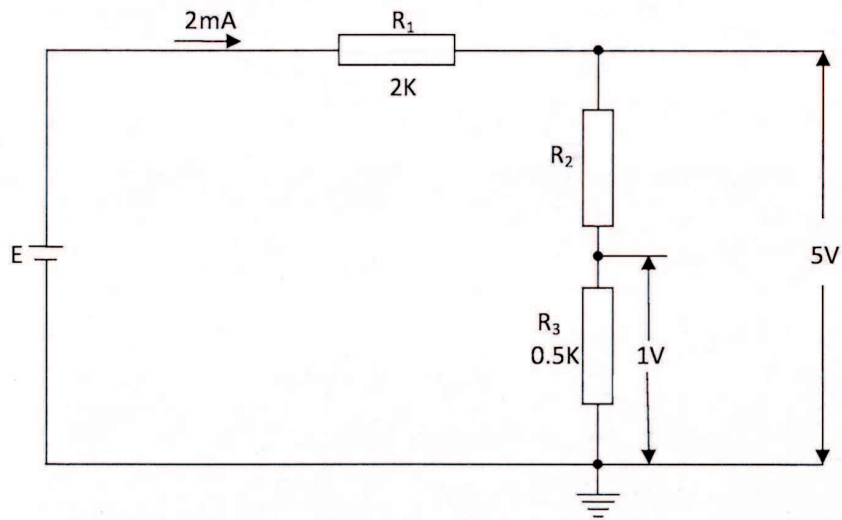

Figure 2

From the circuit shown in **figure 2** calculate the values of: (3 marks)

(a) E

(b) R_2

7 (a) Name **four** accessories used in domestic lighting installation. (2 marks)

(b) State **one** difference between MIMS and PVC sheathed cables. (2 marks)

8 (a) Name **two** types of D.C generators. (1 mark)

(b) With the aid of a diagram, describe the operation of a simple A.C. generator. (5 marks)

9 (a) Perform each of the following number conversions. (2 marks)

(i) 101101_2 to decimal

(ii) 46_{10} to binary

(b) **Figure 3**, shows a symbol of a logic gate.

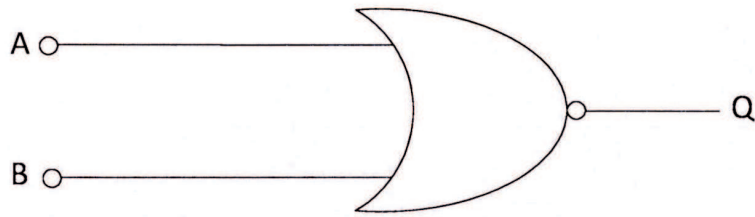

Figure 3

(i) Name the gate. (1 mark)

(ii) Draw and complete the truth table for output Q of the logic gate. (2 marks)

(c) **Figure 4**, shows a basic regulator circuit.

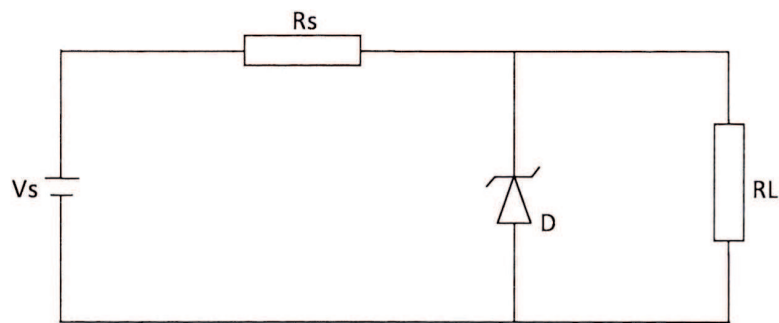

Figure 4

State the effect on voltage across R_L when: (2 marks)

(i) Zener diode is shorted.

(ii) Zener diode open.

- 10 **Figure 5**, shows orthographic views of a block, drawn in first angle projection.

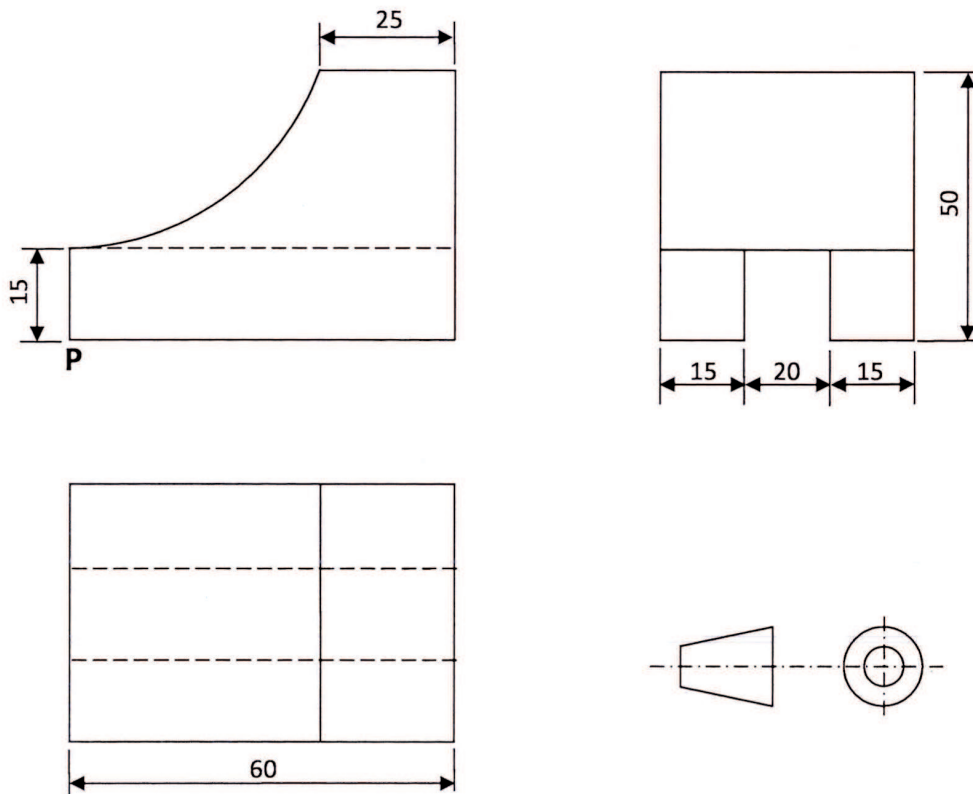

Figure 5

On the isometric grid paper provided, draw the block in isometric projection with P as the lowest point.

(5 marks)

SECTION B (52 marks)

Answer any **four** questions from this section, in the spaces provided.

- 11 (a) With reference to Sinusoidal waveforms, explain each of the following terms: (3 marks)
- Amplitude;
 - Period;
 - Frequency.
- (b) A Sinusoidal voltage trace displayed on an oscilloscope has peak to peak voltage of 24 V and a period of 40 ms. Draw the waveform and calculate: (10 marks)

- (i) Frequency;
- (ii) Average value;
- (iii) RMS value.
- 12** (a) With the aid of a labelled diagram, explain the operation of a split-phase AC motor. (8 marks)
- (b) An ideal transformer is used to step down 480 V to 240 V. The 240 V output is connected to a 24 KW resistive load. Determine the: (5 marks)
- (i) load current;
- (ii) input current;
- (iii) transformer ratio.
- 13** (a) Draw a wiring diagram of a final circuit of one lamp controlled from **three** different points. (4 marks)
- (b) With the aid of a labelled diagram, explain the operation of a switch start fluorescent lamp. (9 marks)
- 14** (a) Describe each of the following processes of making a permanent magnet: (4 marks)
- (i) heating;
- (ii) stroking.
- (b) With the aid of a labelled diagram, explain how a relay operates a high current load. (9 marks)
- 15** (a) Draw and label a schematic symbol for each of the following **two** input logic gates. (3 marks)
- (i) OR
- (ii) NAND
- (b) Construct a truth table for a **two** input NAND gate. (4 marks)
- (c) An electric kettle suddenly stops heating water yet there is power in the socket outlet. Outline the procedure for identifying the possible faults using an ohmmeter. (6 marks)

3.20.2 Electricity Paper 2 (448/2)

1 EXERCISE 1

Use the circuit, equipment and component provided to perform the following tasks.

- (a) Connect the resistors labelled A across point X and Y of the circuit.
- (b) Set the stopwatch to zero.
- (c) Press switch S until voltage reading settles at about 10V.
- (d) Release push button switch S and time the duration it takes for the voltage to drop to about 3-7 V and record the time in **Table 1**.

Table 1

Resistor	A	B	C	D	E
Time (s)					

- (e) Repeat tasks (a) to (d) for each of the resistors B, C, D and E. (12 marks)
- (f) Use schematic symbols to draw the circuit and label the components. (6 marks)
- (g) From the results obtained, calculate the value of resistor labelled E. (2 marks)

2 EXERCISE 2

Using the materials, tools and equipment provided, fabricate the candle stand shown in **figure 1**. Its dimensions are given in the layout. (20 marks)

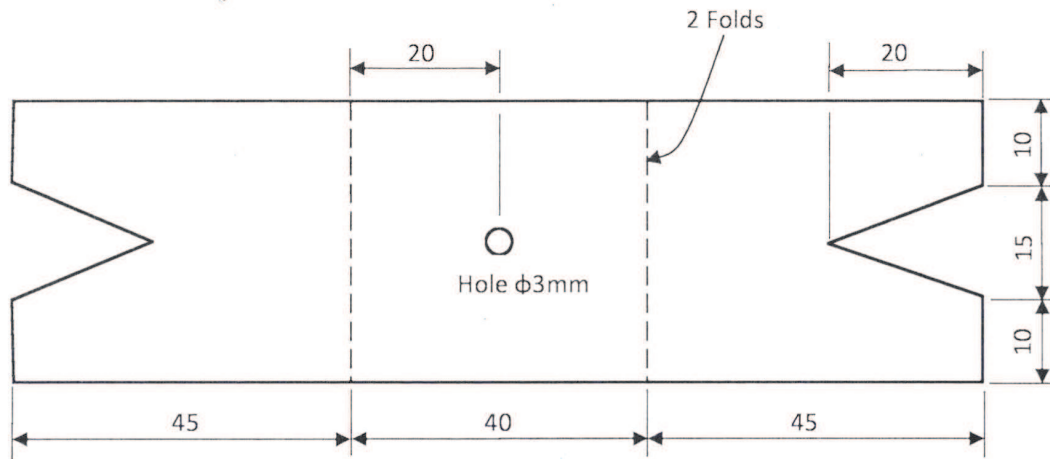

LAYOUT

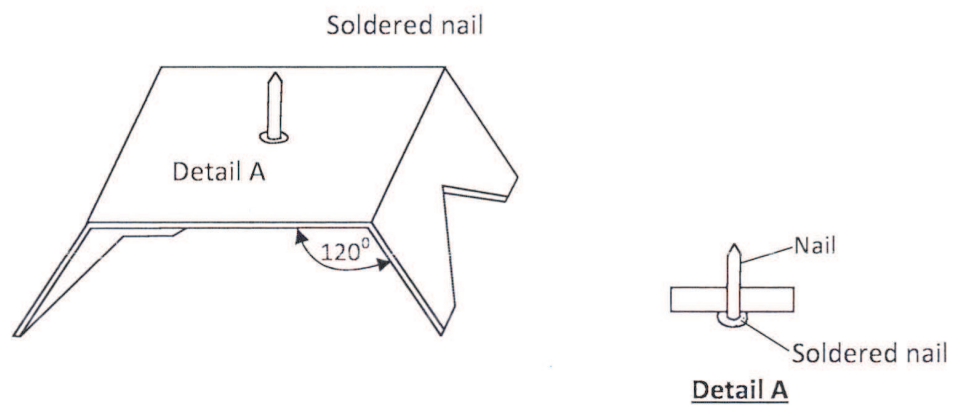

Figure 1

3 EXERCISE 3

Using the components, materials and equipment provided, perform the following tasks.

- (a) Connect the circuit shown in **figure 2** and let the examiner check your work.

(6 marks)

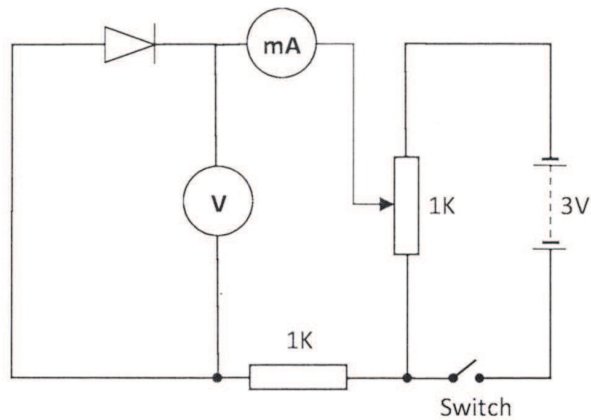

Figure 2

- (b) Close the switch. Adjust the potentiometer to obtain voltage reading shown in **Table 2**. For each voltage obtained, measure and record the corresponding current values.

(5 marks)

Table 2

Voltage (V)	0	0.5	0.7	0.9	1.3	1.7
Current (mA)						

- (c) Plot a graph of current against voltage.

(6 marks)

- (d) From the graph:

- (i) determine the resistance when the voltage is 1.3 V;
- (ii) give a reason for the shape of the graph.

(3 marks)

4 EXERCISE 4

Using the pre-fabricated circuit provided in figure 3, perform the following tasks:-

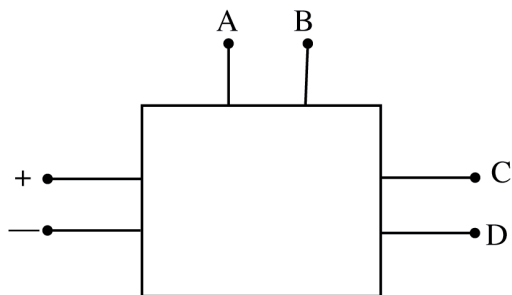

Figure 3

- (a) With the switch open:
 - (i) connect the milliammeter between **A** and **B**.
(observe the polarity).
 - (ii) connect the voltmeter between **C** and **D**.
(observe the polarity).

(2 marks)

(Let the examiner check your work)

- (b) Close the switch

Adjust the variable resistor to obtain the current values in Table 3 and in each case measure and record the corresponding voltage values. (10 marks)

Table 3

Current (mA)	2	4	6	8	10
Voltage (V)					

- (c) (i) Plot the graph of current against voltage.
- (ii) Use the graph to determine the value of current when the voltage is 5.5 V.

(8 marks)

5 EXERCISE 5

Figure 4 shows a lighting circuit. Using materials, tools and equipment provided, instal the circuit such that the switch controls the lamp. (20 marks)

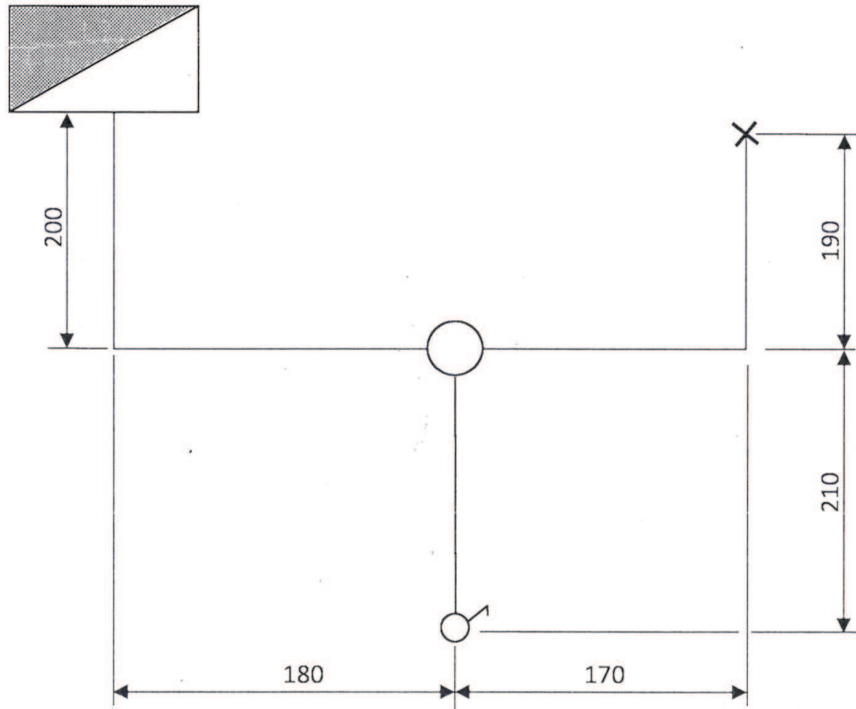

Fig. 4