

5.4 BUILDING CONSTRUCTION (446)



MANYAM FRANCHISE
Discover! Learn! Apply

5.4.1 Building Construction Paper 1 (446/1)

1 (a) To differentiate between a **flat roof** and a **pitched roof**:

- A flat roof with a pitch 10° or less than 10° to the horizontal base.

(1 mark)

- Pitched roof refers to any roof whose angle of slope to the horizontal lies between 10° and 70° .

(1 mark)

Plain concrete Roofing Tile

(b)

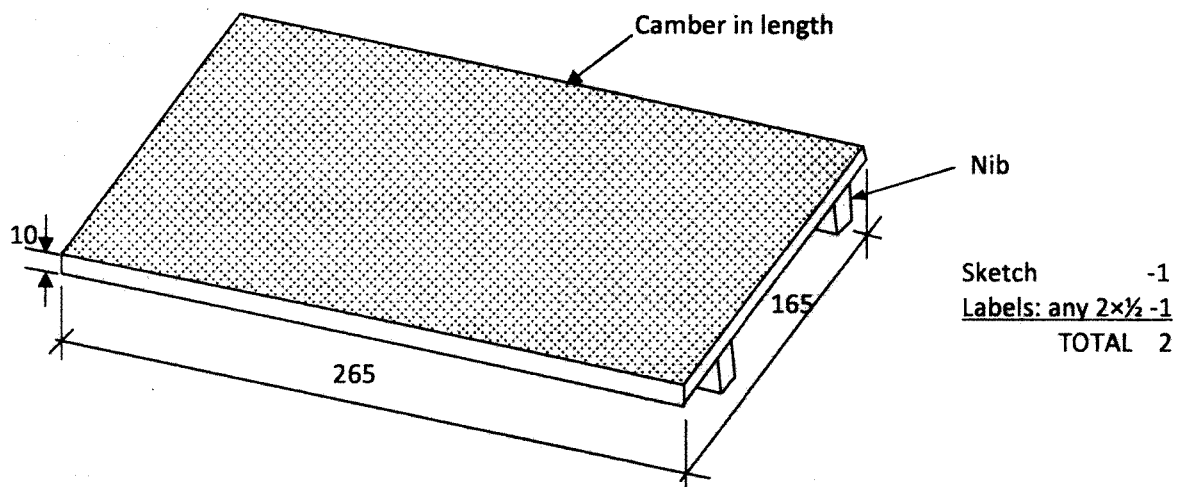

2. (a) **Two** reasons why the current **traditional houses** are better than caves.

- better living conditions.
- caves had no option of design.
- caves are not found everywhere.

Any 2 x $1\Box = 1$ mark

(b) To distinguish between a turning piece and a centre piece.

(i) Turning piece:

Is a small timber or metal support for holding the weight of the arch during construction.

It is a member used to support arches during construction to a distance not more than one metre in span, hence used for light arch work construction. It has no laggings.

($1\Box$ marks)

(ii) Centre piece:

Is also a temporary support. Holds larger units in wider or longer spans. It has ribs with laggings spanning across the ribs for provision of strength. It is larger/bigger than the Turning piece.

(Accept sketches)

($1\Box$ marks)

3. (a) **One function of:**

Cornice - Timber mouldings used to cover the junction between the wall and the ceiling.

Dado rail - Horizontal timber mouldings fixed in a position to prevent the walls from being damaged by the back of chairs.

2 x 1 = 2 marks

(b) **Four places where a vertical d.p.c. may be placed are:**

- (i) Reveals of door and window openings.
- (ii) Retaining walls.
- (iii) Basement walls.
- (iv) Parapet walls.
- (v) Boot lintels in openings.

Any 4 x = 2 marks

4. (a) **Recommended minimum heights above finished floor level:**

- Switch 1400mm
- Wall socket outlet 325mm

2 x 1 = 2 marks

(b) **Advantages of using matt paint finish.**

- Avoid reflection of light sources.
- Do minimise surface irregularities if any.

2 x 1 = 1 mark

Advantages of using gloss paint finish.

- Provides maximum washability.
- Are durable

(2 x) = 1 mark

5. (a) **Advantages of timber scaffolds over steel scaffold.**

- In areas where timber is available, it is cheap and easy to obtain.
- No fittings required.
- No extra maintenance costs.
- Easily cut to size.
- Wastes and old components can be sold as fire wood and make some money.

Any 4 x 1 = 2 marks

(b) **Four** activities that must be carried out immediately a contractor takes possession of a site.

- Fencing the site.
- Clearing the site.
- Setting out the building.
- Establishing a datum level.
- Constructing site huts

Any 4 x \square = 2 marks

6. Procedure of constructing a footpath pavement finished with a precast concrete slab.

- Remove the top soil.
- Fill it up with granular material
- Compact the surface fully to the required gradient
- Lay the pre-cast concrete slab

4 marks

7. (a) Sketches to show:

Intermediate profile

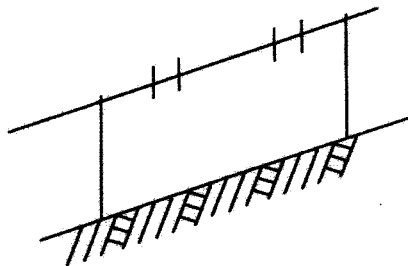

Intermediate profile

(1 Mark)

Corner profile

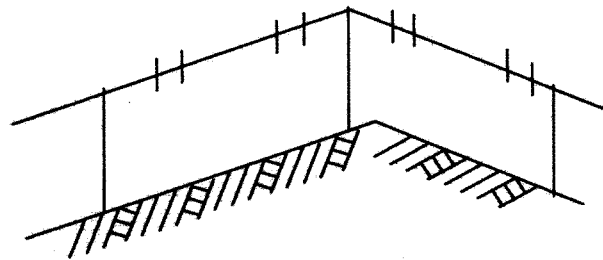

Corner profile

(1 Mark)

(b) Properties of:

Sand

- Free from too much clay
- Well graded
- Free from organic impurities

Any 2 x \square = 1 mark

Water

- Free from impurities
- Free from sulphates
- Clean/palatable

Any 2 x \square = 1 mark

8. Method of establishing uniform depth of a trench bottom using a bonning rod.

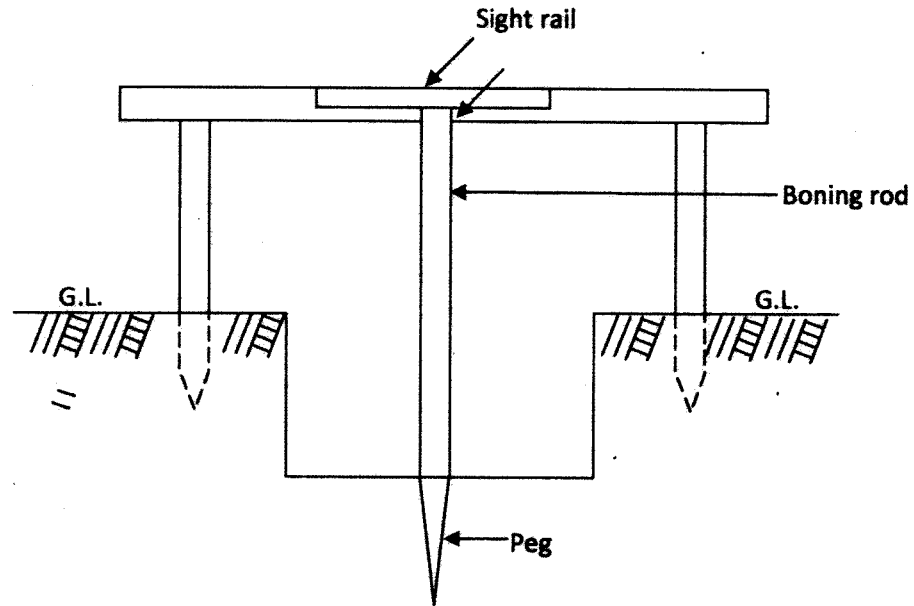

Sketch 2 marks
 Labels 4 x □ = 2 mark
 4 marks

9. (a) Factors considered when selecting site.

- Availability of services
- Orientation of site
- Ease of communication
- Site conditions

Any 2 x □ = 1 mark

(b) Plain scarf joint

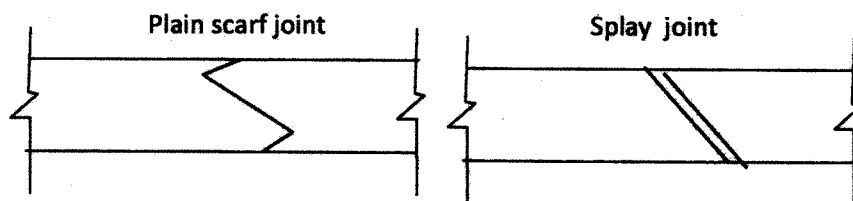

Sketch 1 mark
 Naming 1□ mark
 2 x 1□ = 3 marks

10.

Interpretation 3 Angle = 1 Mark
 Plan = 1 Mark
 Front elevation = 1 Mark
 End elevation = 1 Mark
= 4 Marks

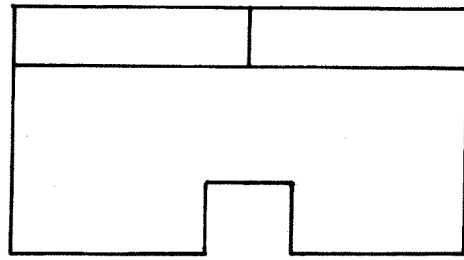

PLAN

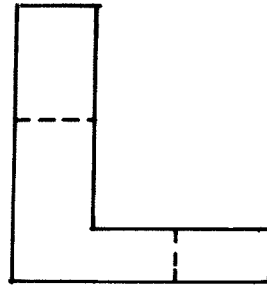

EE

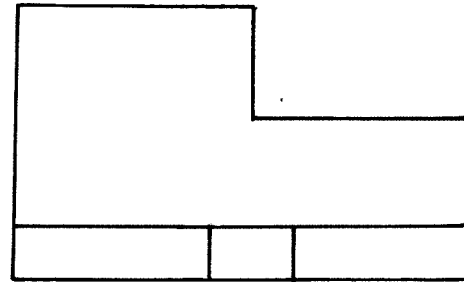

FE

11.

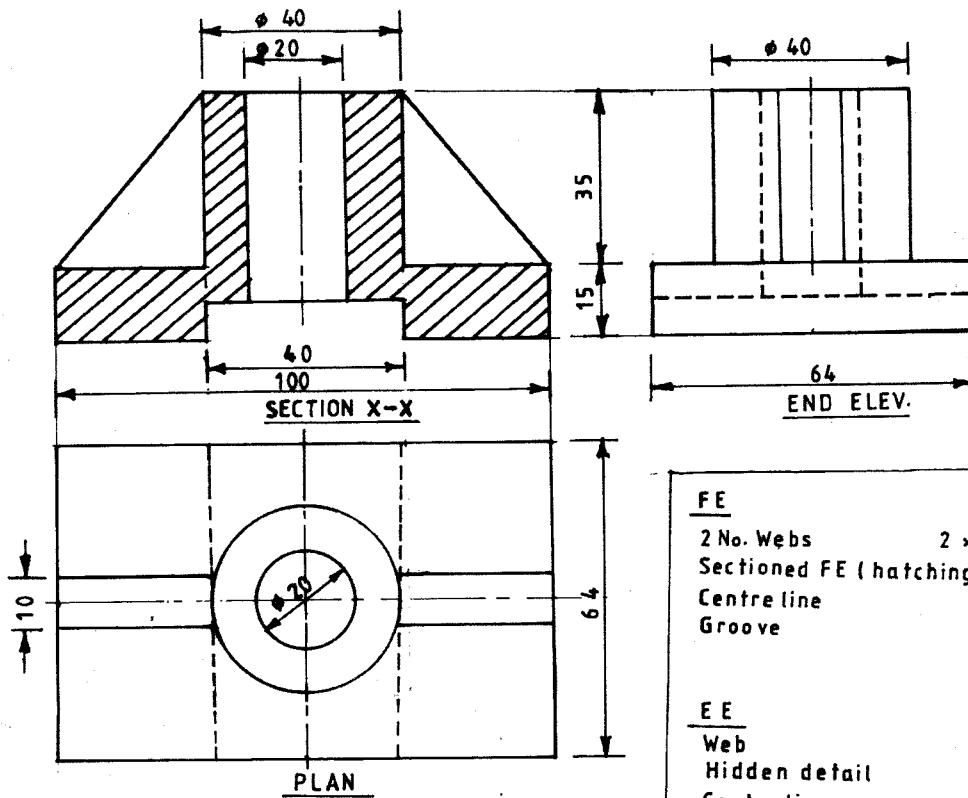

<u>FE</u>	
2 No. Webs	$2 \times \frac{1}{2} = 1$
Sectioned FE (hatching)	= 2
Centre line	= 1
Groove	= 1
	<u>5</u>
<u>EE</u>	
Web	= 1
Hidden detail	= 2
Centre line	= 1
	<u>4</u>
<u>PLAN</u>	
Circles $\phi 40$ & $\phi 20$	= 2
Webs 2 No	$2 \times \frac{1}{2} = 1$
Centre lines	= 1
Hidden detail	= 2
	<u>6</u>

12. Foundation dimensions

- (a) Wall thickness $W = d = \frac{1}{3}$ spread (s)
 $\therefore W = 150 \text{ mm} = d = 150 \text{ mm}$
 If $150 \text{ mm} = \frac{1}{3}S$

mark
 mark
 mark

Then $S = \frac{150}{1} \times \frac{3}{1} = 450 \text{ mm}$

mark

2 marks

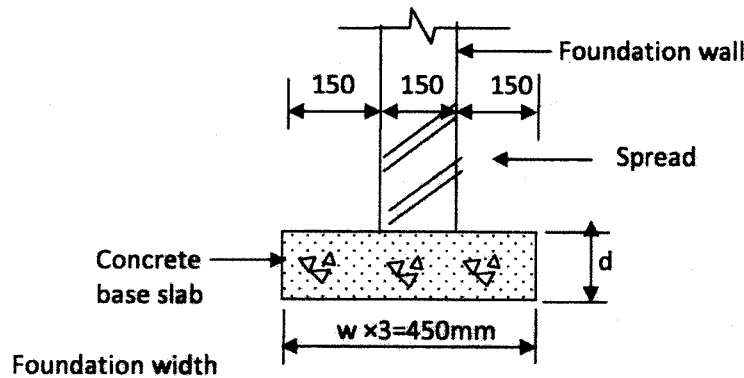

Sketch = 3 marks
 Labels any 2 x = 1 mark
 4 marks
 Total = 6 marks

- (b) (i) Differentiate between a **common rafter** and a **jack rafter**.

- Common rafters are the main load bearing members of a roof, they span between the wall plate at eaves level up to the ridge.

1 mark

- Jack rafters are also load bearing rafters but span from ridge to valley rafter or from hip rafter to wall plate.

1 mark

- (ii) To sketch and label a collar roof.

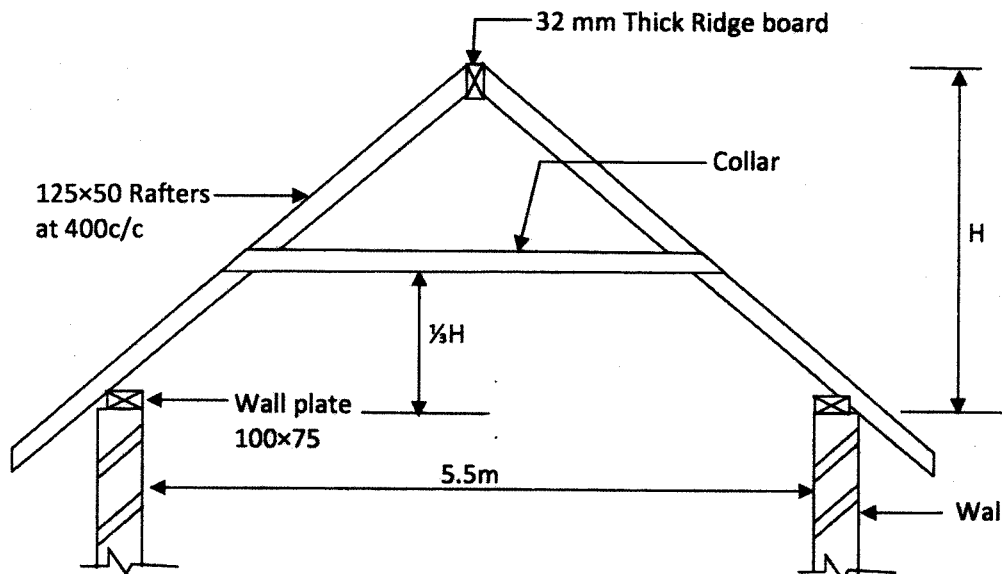

Sketch - 4 marks
 labels any 4 x = 2 marks
 Mandatory requirements = 1 mark
 7 marks

13. (a) Factors to consider when transporting concrete on site:

- distance should be kept to minimum to avoid setting
- container should be watertight
- transport on smooth surface to avoid segregation
- container should be covered when it is raining

Any 3 x 1 = 3 marks

(b) Terminologies used in foundations

Bearing capacity

- This is the safe load per unit area which the ground can carry.

Made ground

- Is refuse, excavated rock or soil deposited for the purpose of filling in a depression or for raising the site above its material level.

2 x 2 = 4 marks

(c) Activities carried out before laying foundations

Levelling the bottom

This is a process of forming levels or ensuring that the bottom of the trench is level. It starts from the lowest point along a run of the trench. Pegs are driven into the bottom and levels taken from peg to peg to ensure they are all level. Raised parts are cut while the low parts are filled.

Consolidation of the bottom

The bottom of the trench is raised or compacted to ensure a solid base. This may reveal pockets in the base which are filled and compacted level with the bottom.

Pegging

Pegs are driven into the bottom of the trench at predetermined distances. These pegs are used in conjunction with the spirit level to ensure a given level for pouring concrete. Concrete is levelled off to the top of the pegs.

Wetting

This is the last preparation done to the bottom of the trench before concrete is poured. Water is sprayed or sprinkled to the bottom of the trench just a few minutes before concreting starts.

4 x 2 = 8 marks

14. (a) Procedure of applying a rough cast finish on a new wall.

- remove any sticking mortar on the wall surface
- clean the mortar joints and remove any protruding mortar on the joints
- fill any holes that may exist along on the wall joint either vertical or horizontal
- sprinkle water on the surface of the wall
- apply the first coat of mortar which should be liquidish using a hard machine sprayer
- apply a second coat with a more thicker coat all over the wall surface
- finish with a third lighter coat to ensure uniform final finish

7 marks

(b) Two methods of fixing a timber door frame to a masonry wall.

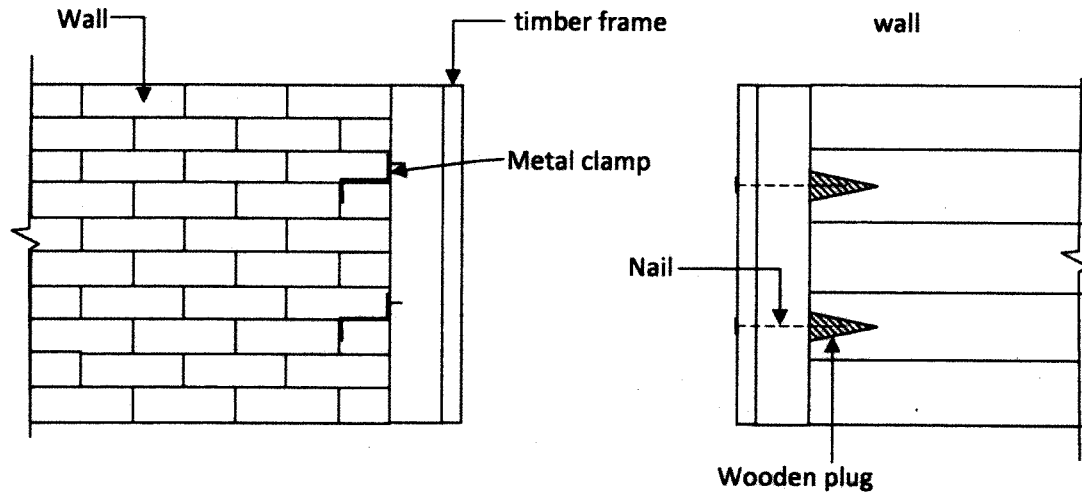

- A metal clamp with a fish tail end is fixed to the back of the frame using wood screws
- A recess/hole is cut in the wall to accommodate the metal clamp and then covered with concrete.
- A hole/recess is cut into the masonry wall to accommodate a wooden plug.
- The plug is driven flush to the wall.
- The frame is nailed to the plug.

Sketches 2 x 2 = 4 marks
 labels any 2 x □ x 2 = 2 marks
 Explanation 1 x 2 = 2 marks
 8 marks

15. Direct cold water supply system

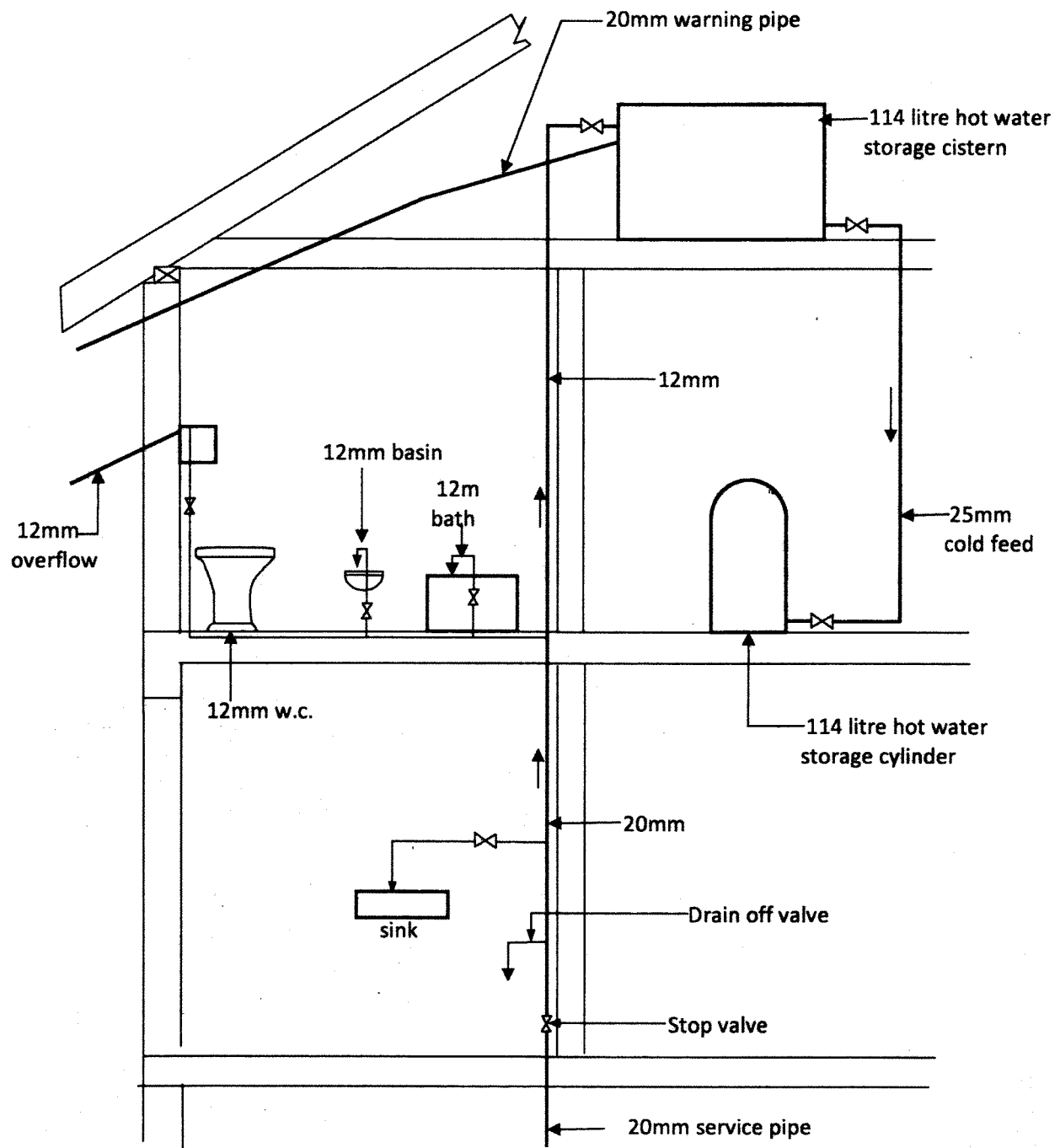

Sketch = 6 marks
 labels any 10 x \square = 5 marks
 Fittings in position any 6 x \square = 3 marks
 Direction of flow any 2 x $\frac{1}{2}$ = 1 mark
 15 marks