

449/1
DRAWING AND DESIGN
Paper 1
Nov. 2016
2½ hours



THE KENYA NATIONAL EXAMINATIONS COUNCIL
Kenya Certificate of Secondary Education
DRAWING AND DESIGN
Paper 1
2½ hours

Instructions to candidates

- (a) *You should have the following for this examination:*
 - Answer sheet;*
 - Drawing instruments;*
 - 3 sheets of drawing paper size A3;*
 - Scale rule.*
- (b) *This paper consists of **three** sections: A, B and C.*
- (c) *Answer **all** the questions in sections A and B and any other **two** questions from section C.*
- (d) *Questions in section A must be answered on the answer sheet provided.*
- (e) *Questions in section B and C should be answered on A3 sheets of drawing paper provided.*
- (f) *All dimensions are in millimetres unless otherwise stated.*
- (g) *Candidates may be penalised for not following the instructions given in this paper.*
- (h) *This paper consists of 10 printed pages.*
- (i) *Candidates should check the question paper to ascertain that all the pages are printed as indicated and that no questions are missing.*
- (j) *Candidates should answer the questions in English.*



SECTION A (50 marks)

Answer **all** the questions in this section on the answer sheet provided.

1. (a) State **one** disadvantage of using each of the following items to hold paper on the drawing board.
- (i) Marking tape
- (ii) Thumb pins (2 marks)
- (b) (i) Give **one** disadvantage of oral communication when representing an engineering object.
- (ii) Give **one** reason for observing established standards in manufacturing industry. (2 marks)
2. (a) Sketch each of the following lines:
- (i) Hidden detail
- (ii) Folding line
- (iii) Centre line
- (iv) Cutting plane (2 marks)
- (b) State the meaning of each of the symbols shown in **Figure 1**.

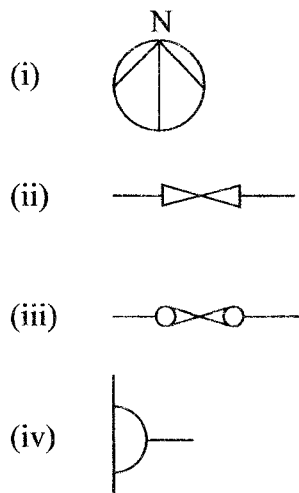

(4 marks)

Figure 1

3. (a) **Figure 2** shows an elevation of a template.

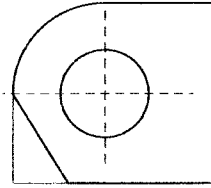

Figure 2

Measure the dimensions for the:

- (i) Circle
- (ii) Radius
- (iii) Angle of the slanting face (3 marks)
- (b) List six computer programs that can be used to produce a drawing. (3 marks)
4. (a) Define each of the following properties of materials:
- (i) plasticity
- (ii) elasticity (2 marks)
- (b) State **four** ways in which design ideas are communicated. (2 marks)
5. (a) List **four** factors to consider when lettering. (2 marks)
- (b) State **three** effects of poor disposal of engineering materials to the environment. (3 marks)



6. Enlarge **Figure 3** (ABCD) in the ratio of 5:7 (4 marks)

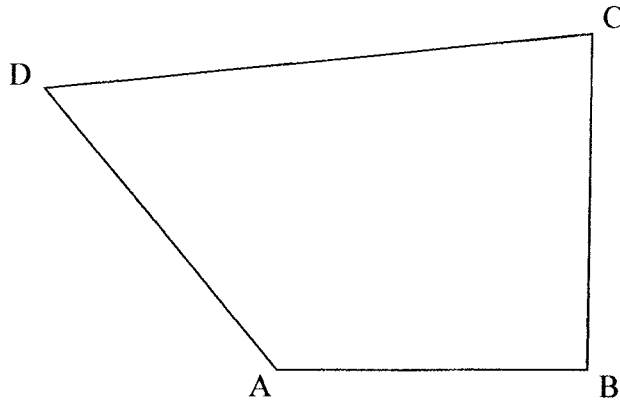

Figure 3

7. Construct a triangle whose perimeter is 240 mm and the sides are in the ratio 4.5:6.0:7.5. Measure the smallest angle. (5 marks)

8. **Figure 4** shows the front elevation and incomplete plan of a truncated square-based pyramid.

- (a) complete the plan.
 (b) draw the true shape of the cut face.

(5 marks)

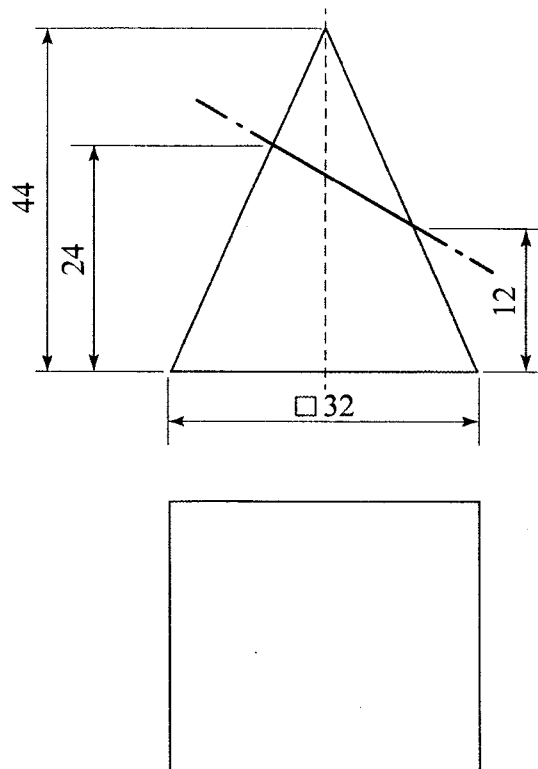

Figure 4

9. **Figure 5** shows two views of a machined bracket drawn in first angle project.

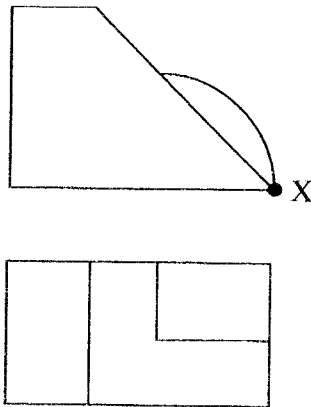

Figure 5

Sketch in good proportion, the isometric view of the block taking X as the lower point.

(5 marks)

10. **Figure 6** shows two views of a block drawn in first angle project. In good proportion sketch the block in oblique projection. (6 marks)

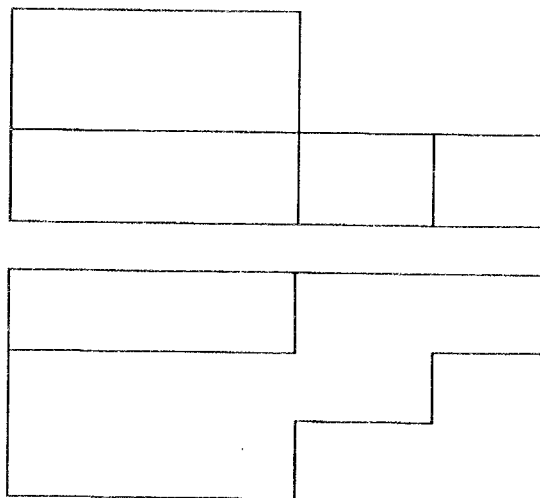

Figure 6



SECTION B (20 marks)

Question 11 is compulsory

It should be answered on the A3 paper provided.

11. **Figure 7** shows parts of a machine component drawn in first angle projection. Assemble the parts and draw, FULL SIZE, the following:

- (a) sectional front elevation along the cutting plane B-B;
- (b) end elevation.

Insert three leading dimensions.

Unspecified dimensions are left to the candidate's discretion. Hidden details are not required.

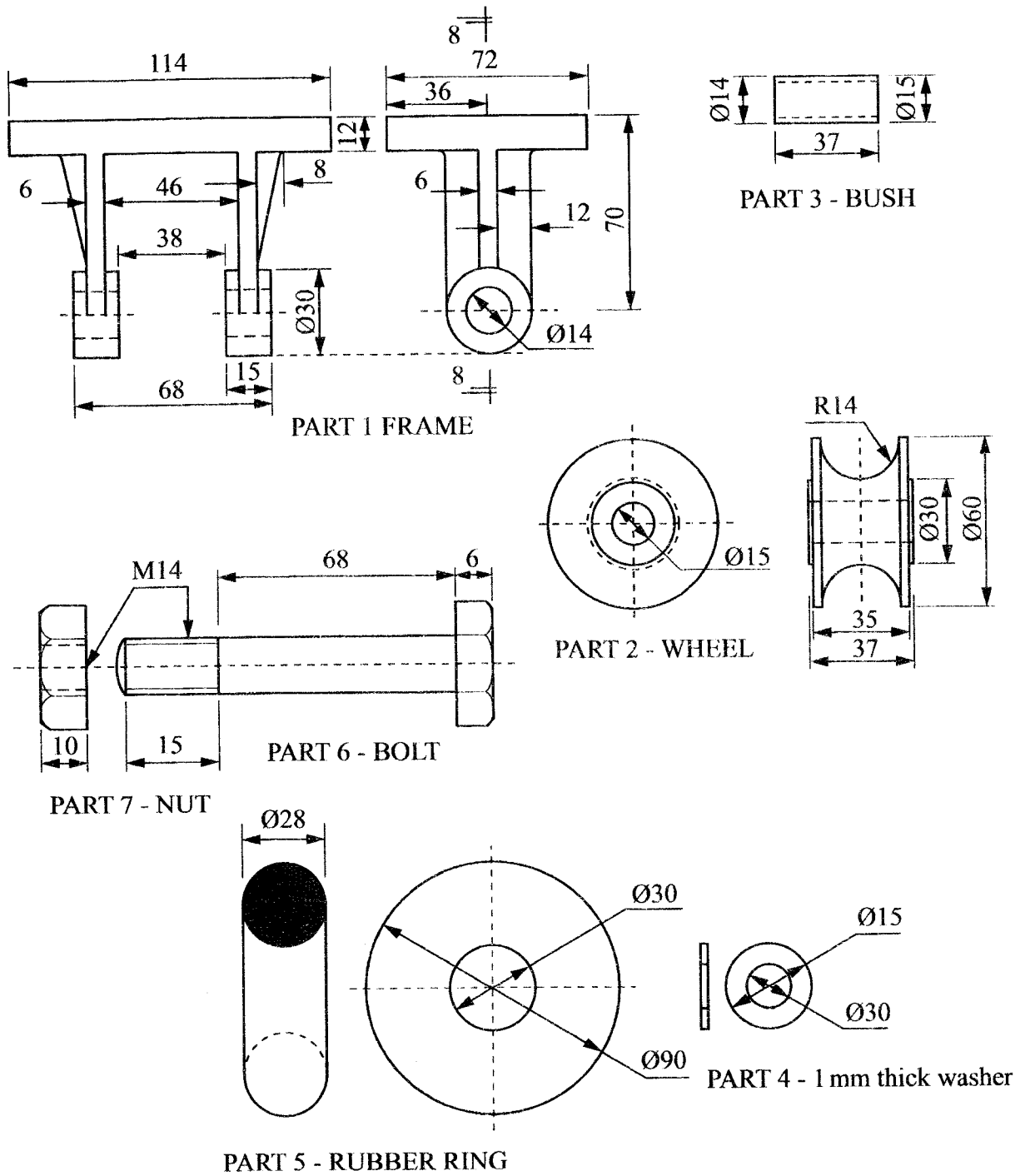

- Dimensions in mm
- Drawing not to scale

Figure 7

SECTION C (30 marks)

Answer any *two* questions from this section on the A3 paper provided.

12. In the mechanism shown in **Figure 8**, the crank EF rotates about centre E while GH oscillates about G.

Plot the locus of point P for one complete revolution of EF.

(15 marks)

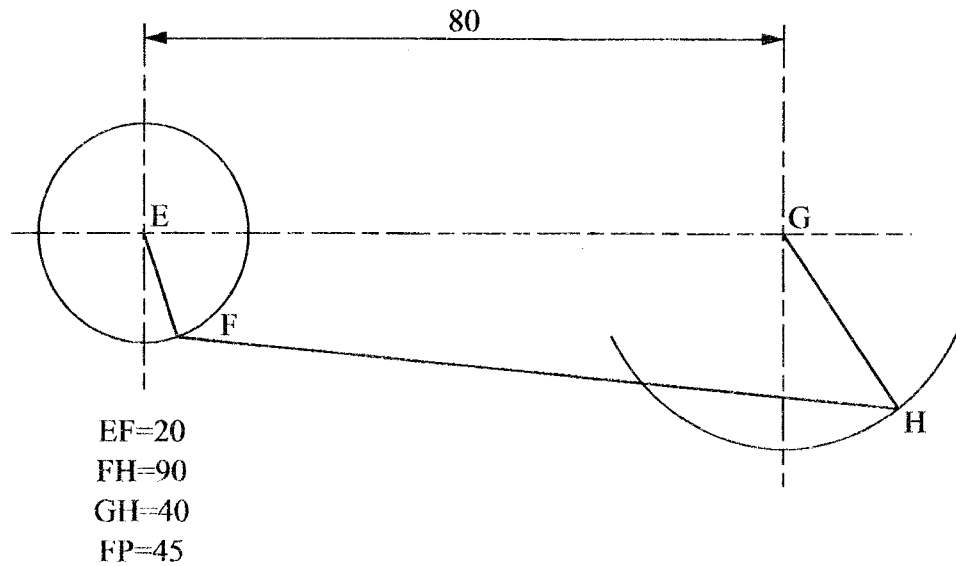

Figure 8

13. Figure 9 shows two intersecting square tubes A and B drawn in first angle projection.

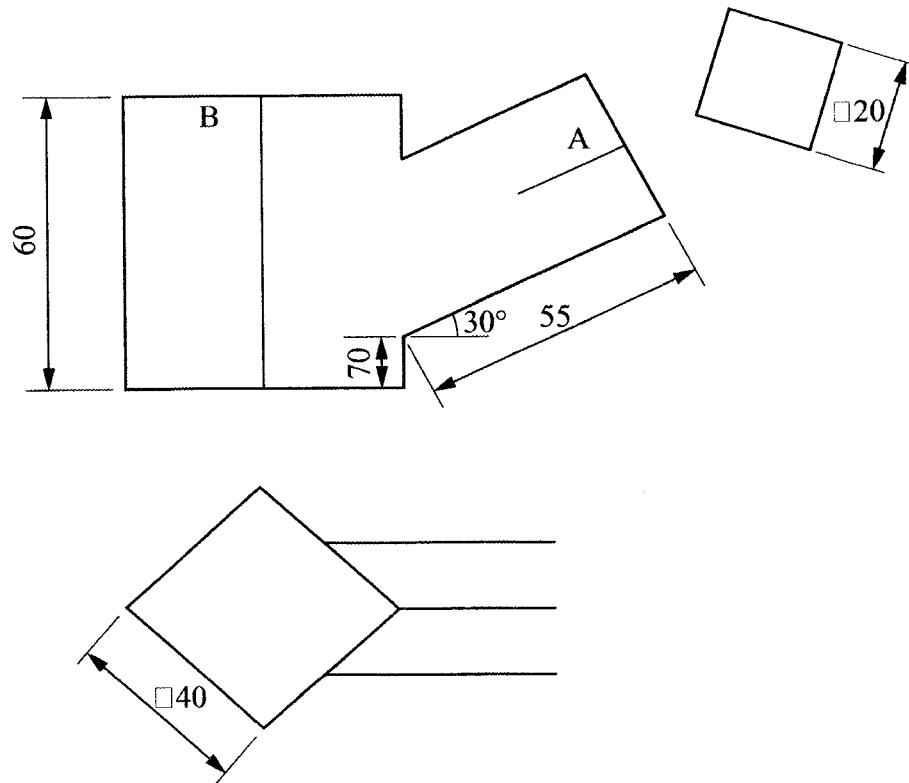

Figure 9

(a) copy the figure and complete:

- (i) the front elevation;
- (ii) the plan.

(b) Draw the development of tube B.

(15 marks)



14. **Figure 10** shows an inclined plan of a block and its front elevation.

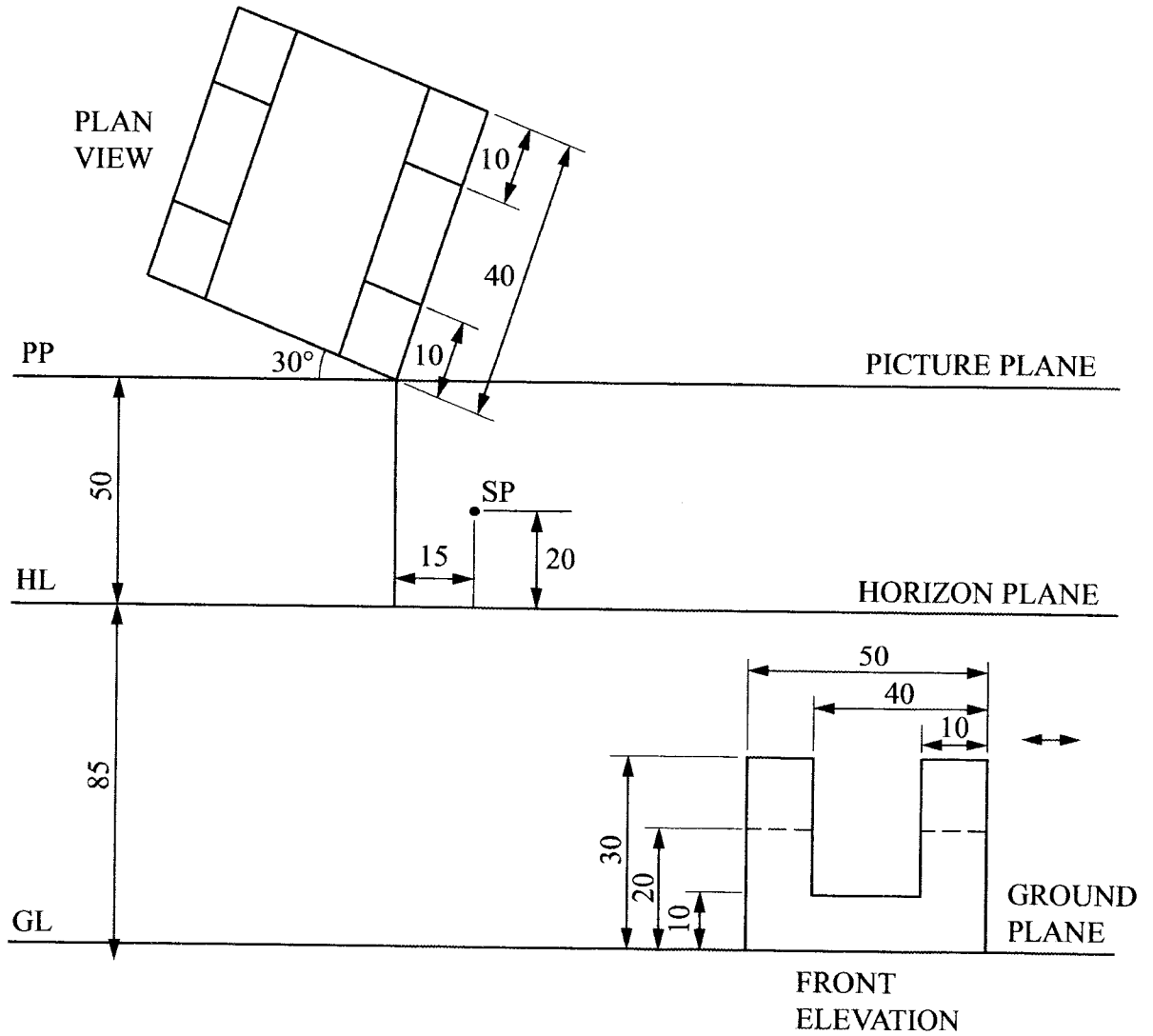

Figure 10

Copy the given layout and draw the two point perspective of the block showing all construction details. (15 marks)

THIS IS THE LAST PRINTED PAGE.