

4.3 METALWORK (445)

4.3.1 Metalwork Paper 1 (445/1)

SECTION A (40 marks)

Answer all questions in this section in the spaces provided.

1. (a) Give **four** factors to consider when applying for a job. (2 marks)
(b) Outline **four** guidelines for employers when engaging new employees after advertising. (2 marks)
2. (a) State **four** safety precautions to observe when using a grinding machine. (2 marks)
(b) Give **four** methods of identifying different types of metals in a workshop. (2 marks)
3. (a) State **four** factors to consider when planning and designing an item for manufacturing. (2 marks)
(b) Outline the procedure of taking readings on a vernier calliper. (3 marks)
4. List **four** accessories that comprise the combination set. (2 marks)
5. (a) State **three** factors that contribute to the success and accuracy of metal removal using hand tools. (3 marks)
(b) Name **two** metals used for coating mild steel sheets and in each case, state the material produced. (3 marks)
6. Using sketches, show the effect of each of the following in riveting. (3 marks)
(a) Failure to use a rivet set in riveting.
(b) Drilling a large rivet hole
7. State **four** advantages of brazing over gas welding. (4 marks)
8. List **three** methods of testing welds in each of the following categories: (3 marks)
(a) Non-destructive tests.
(b) Destructive tests.
9. Outline the procedure of centre drilling a workpiece on the lathe machine. (3 marks)
10. (a) Sketch **two** types of hammers commonly used in forging and state the function. (4 marks)

- (b) Outline the procedure of oil blacking as a method of finishing metallic items. (2 marks)

SECTION B (60 marks)

Answer question 11 on the A3 paper and any other three questions from this section in the spaces provided. Candidates are advised to spend not more than 25 minutes on question 11.

11. Figure 1 shows a machine block drawn in isometric projection.

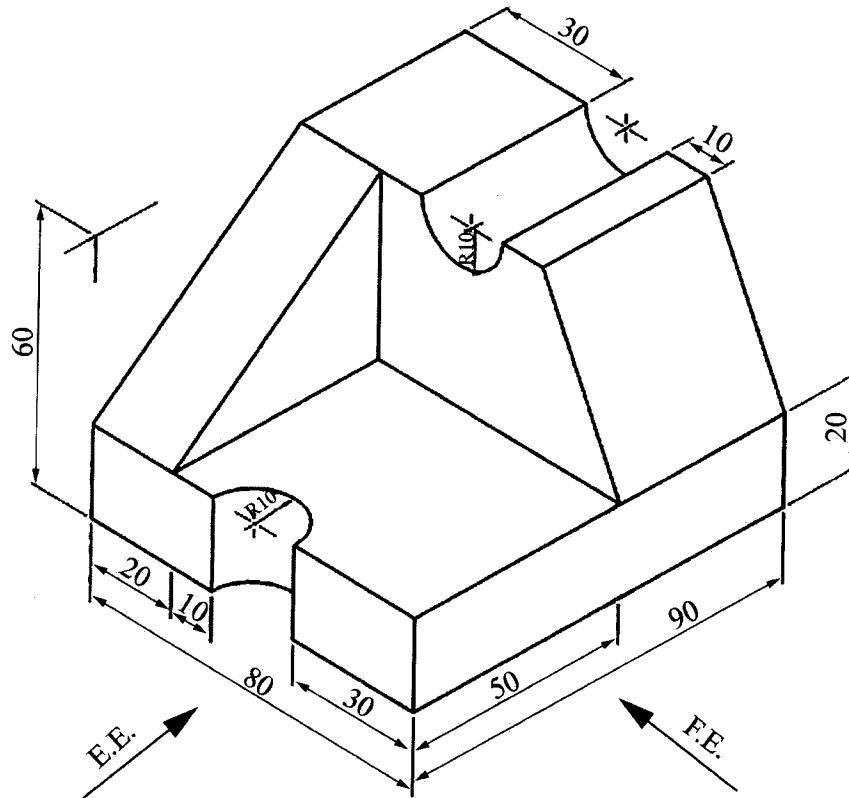

Figure 1

Draw Full Size in first angle projection the following views of the block: (15 marks)

- Front elevation as viewed in the direction of arrow F.E.
 - End elevation as viewed in the direction of arrow E.E.
 - The plan.
12. (a) With the aid of sketches outline the procedure of finding the centre of a round bar using a surface gauge. (10 marks)
- (b) State five safety precautions to be observed when using taps and dies. (5 marks)
13. (a) Outline the procedure of riveting two plates using two snap head rivets. (10 marks)

(b) Give **two** major classifications of fluxes used in soldering. (1 mark)

(c) State **four** functions of fluxes in soldering. (4 marks)

14. **Figure 2** shows a portion of three pipes diameter 24 mm joined at 45° at two positions. Draw the development of pipe **B**. (15 marks)

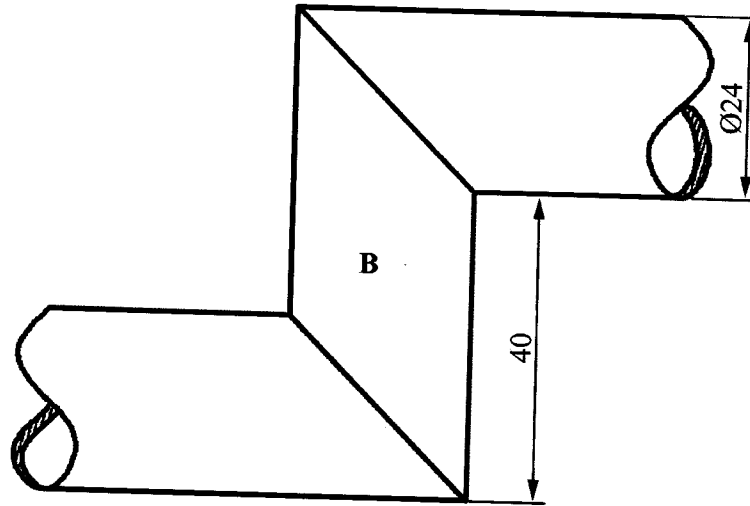

Figure 2

15. (a) Explain how the cutting point on an ordinary lathe tool bit is ground to allow for efficient cutting. (2 marks)
- (b) Give **four** classifications of lathe tools. (4 marks)
- (c) **Figure 3** shows a component to be made from a square plank $25 \times 25 \times 80$ mm long.

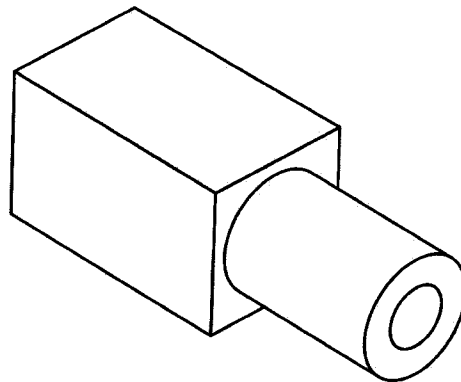

Figure 3

Outline the procedure of making the component on a lathe machine. (9 marks)