

3.7 DRAWING AND DESIGN (449)

The Drawing and Design for the year 2019 was tested in two papers: Paper 1 (449/1) and Paper 2 (449/2). The paper 1 was a theory paper which constituted 60% of the final mark while paper 2 was a practical paper which constituted 40% of the final mark. The format and weighting of the papers was the same as in the previous years.

Candidates Overall Performance

Table 13: Candidates' overall performance in the last six years

Year	Paper	Candidature	Maximum scores	Mean Score	Standard Deviation
2014	1		60	36.82	10.21
	2		40	30.13	5.61
	Overall	466	100	66.95	14.09
2015	1		60	35.00	11.16
	2		40	27.05	6.41
	Overall	570	100	62.05	15.61
2016	1		60	38.61	11.00
	2		40	28.32	5.77
	Overall	612	100	66.92	14.91
2017	1		60	34.95	10.47
	2		40	29.56	4.94
	Overall	715	100	64.51	13.86
2018	1		60	36.8	11.37
	2		40	30.81	5.47
	Overall	742	100	67.61	15.45
2019	1		60	36.77	11.42
	2		40	31.27	5.57
	Overall	899	100	68.04	15.24

From the table above, the following observations can be made;

- (i) The candidature increased from 742 in the year 2018 to 899 in the year 2019.
- (ii) The mean score improved from 67.61 in 2018 to 68.04 in the year 2019.
- (iii) The standard deviation decreased from 15.45 in 2018 to 15.24 in the year 2019.

3.7.1 Drawing and Design Paper 1 (449/1)

The questions which were reported to have been poorly responded to have been analyzed with a view to pointing out candidates' weaknesses and propose suggestions on some remedial measures that need to be taken in order to improve performance in future. The questions for discussions include 2, 7, 12 and 13.

Question 2

- (a) Name **two** instruments used for drawing vertical lines.
- (b) State **two** uses of dividers in technical drawing.

Weakness

Some candidates failed to name drawing instrument while others could not state the uses of a divider.

Advice to teachers

Teachers are advised to cover the syllabus adequately and clearly explain to the students the appropriate use of each drawing instrument.

Expected responses

Two instruments for drawing vertical lines

- T – square
- Set - square

(Any 2 x ½ = 1 mark)

Use of dividers

- Transferring measurements from the ruler to the drawing or from one drawing to another
- Stepping off a series of equal distances.

(Any 2 x 1 = 2 marks)

Question 7

Make pictorial sketches of the following fastening devices:

- (a) Gib head key
- (b) Woodruff key
- (c) Feather key

Weakness

Some candidates could not sketch the fastening devices

Advice to teachers

Teachers are advised to cover the syllabus adequately including the topic of fastening devices.

Expected responses

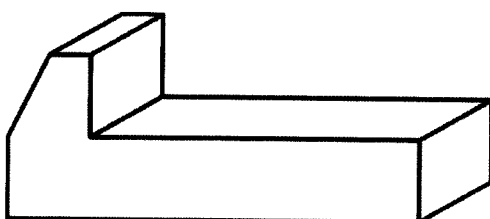

Gib head key

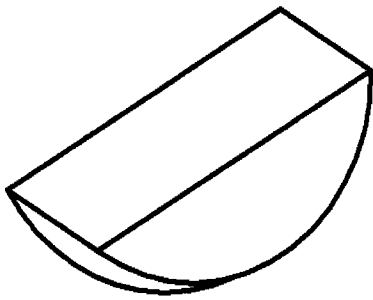

Woodruff key

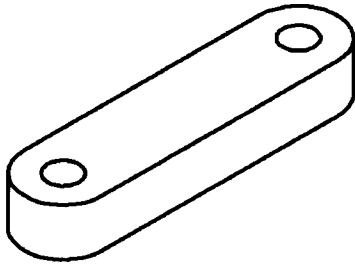

Feather key

Question 12

Figure 7 shows two views of an axle boss drawn in first angle projection. Draw the boss in isometric projection taking X as the lowest point. (15 marks)

Include six dimensions.

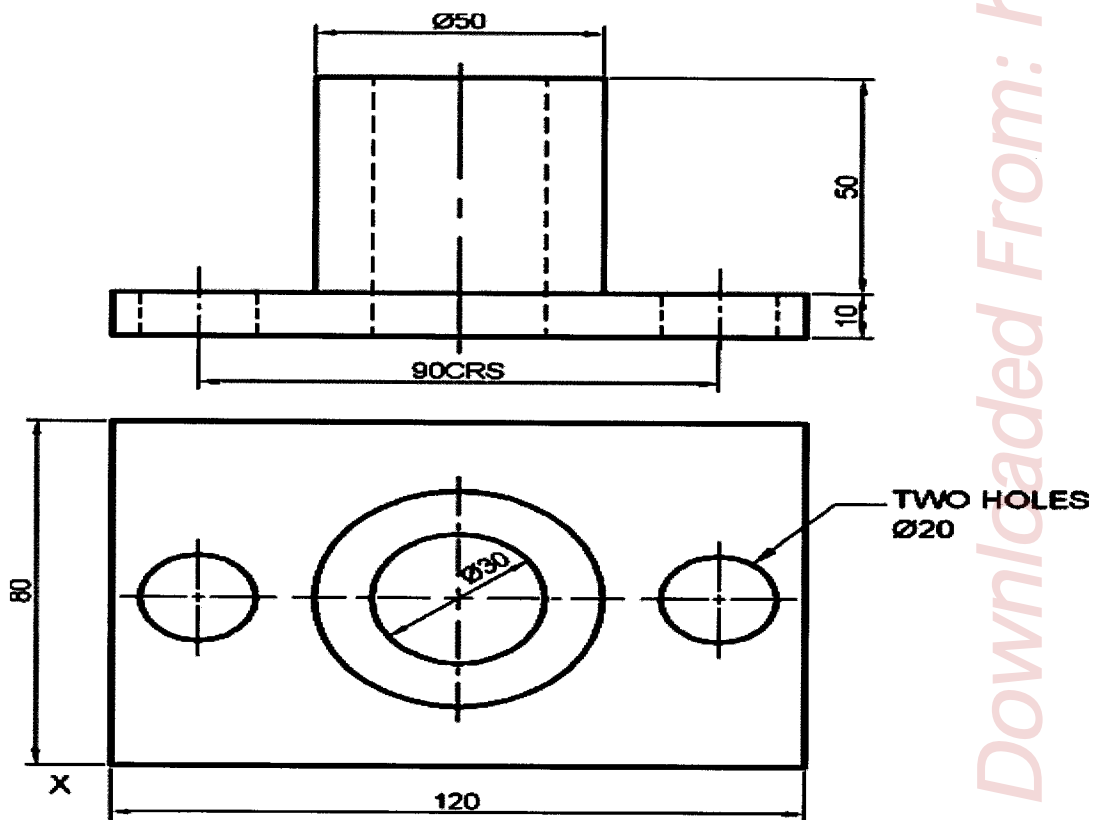

Weakness

Some candidates could not draw the block in isometric projection by interpreting the views given in orthographic projection and especially the isometric circles

Advice to teachers

Teachers are advised to adequately cover the syllabus and give the students a lot of exercises for practice.

Expected responses

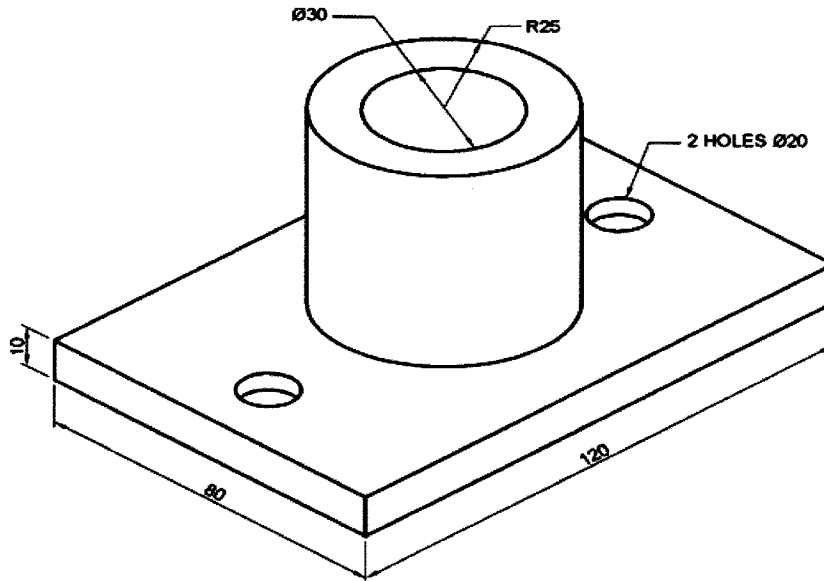

Question 13

Figure 8 shows an elevation of a joint formed by two pipes A and B at a right angle. Draw the development of the pipes. (15 marks)

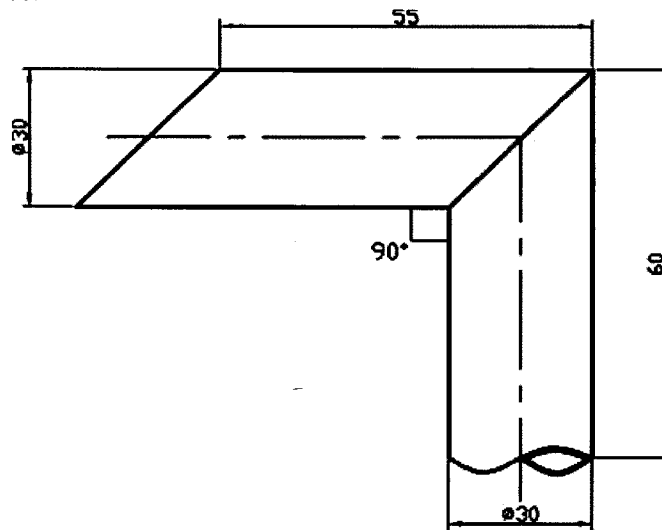

Weakness

Some candidates could not draw the surface development of the pipes as they appeared in the question.

Advice to teachers

Teachers are advised to give students more practice in drawing the development of pipes intersecting at different points and different angles.

Expected responses

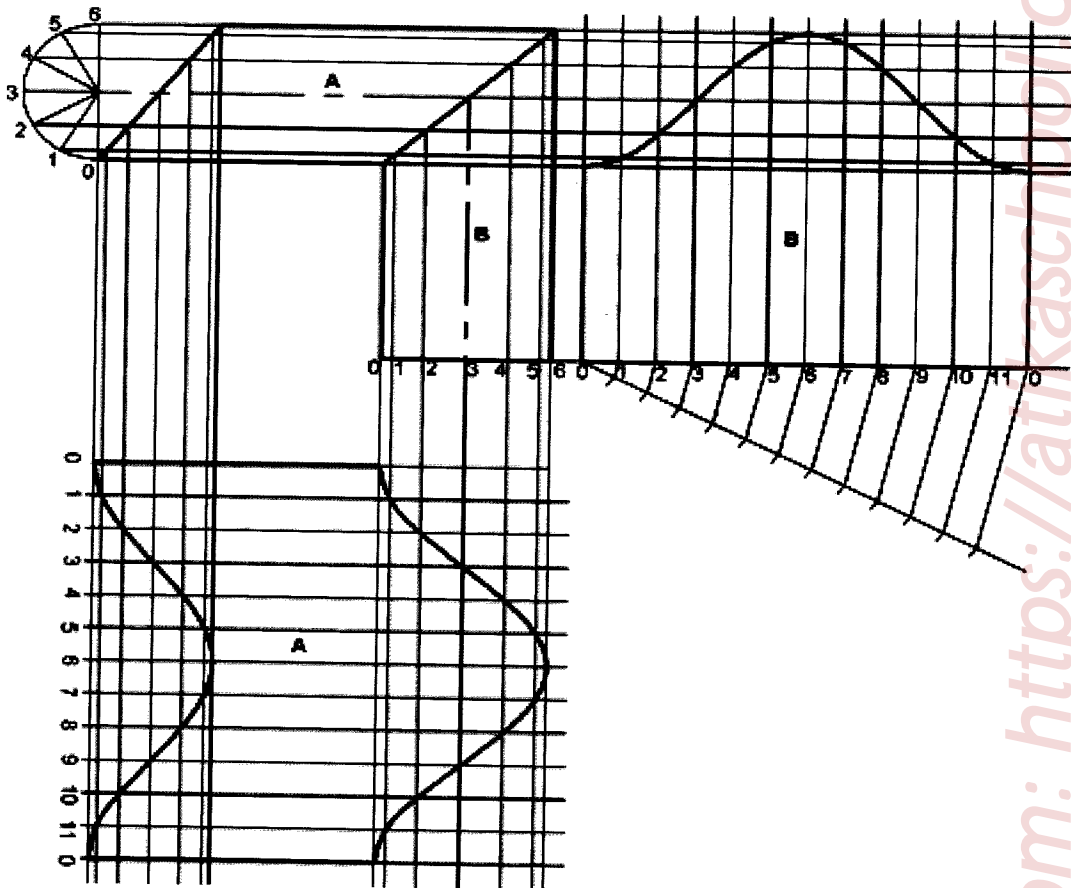

Copying of figures – 1

Drawing circle and dividing – 1

Projections from circle into figure – Vertical – 1

Horizontal - 1

Part A and B

- Determining circumference $2 \times 1 = 2$
- Dividing circumference into 12 parts $2 \times 1 = 2$
- Vertical projections $2 \times 1 = 2$
- Horizontal projections $2 \times 1 = 2$
- Plotting of points $2 \times \frac{1}{2} = 1$
- Joining the points $2 \times 1 = 2$

=15 marks

3.7.2 Drawing and Design Paper 2 (449/2)

This paper is always composed of one design question which must be attempted by all the candidates. In 2019, the paper required the candidates to design a camping bed with the following considerations:

1. It should be collapsible and convenient to carry around.
2. It should have standard length and convenient height.
3. It should be stable when in use.

The tasks which the candidates were to carry out were as follows:

- (a) Make free-hand pictorial sketches of two possible designs.
- (b) Select **one** of the designs in (a) above and make a refined labelled pictorial drawing.
- (c) Make detailed exploded sketches of the mechanism used in considerations (1) and (3) above.
- (d) Name **two** types of materials used in the design and state where each is used.
- (e) State **two** methods of joining applicable in the design.

Weaknesses

- Some candidates lacked skills to produce proportional sketches of possible designs.
- Some candidates failed to label the drawings while others drew in orthographic instead of isometric projection.
- Some candidates failed to show the exploded parts for appropriate mechanisms to achieve the considerations.
- Some candidates were not specific when naming the materials to be used in the design.
- Some candidates gave unrealistic methods of joining different parts like ropes, end bolts and rubber bands.

Advice to teachers

- Give students a lot of practice in sketching and presenting various ideas in form of drawings.
- Expose candidates to various designs in order to develop the desired concepts.
- Always insist on neatness, line work and proportionality in all the drawing assignments given to students.
- Insist on strict adherence to the instructions given.
- Ensure that the entire syllabus is covered including topics like materials, their properties and methods of joining different parts.