

4.8.2 Aviation Technology Paper 2 (450/2)

STATION 1

INSTRUCTIONS

Figure 1 shows an exploded view of a hydraulic system hand pump. In the space provided:

- (a) sketch in good proportion a typical pictorial view of the hand pump. (8 marks)
- (b) name **four** visible parts on Figure 1 after assembly. (2 marks)

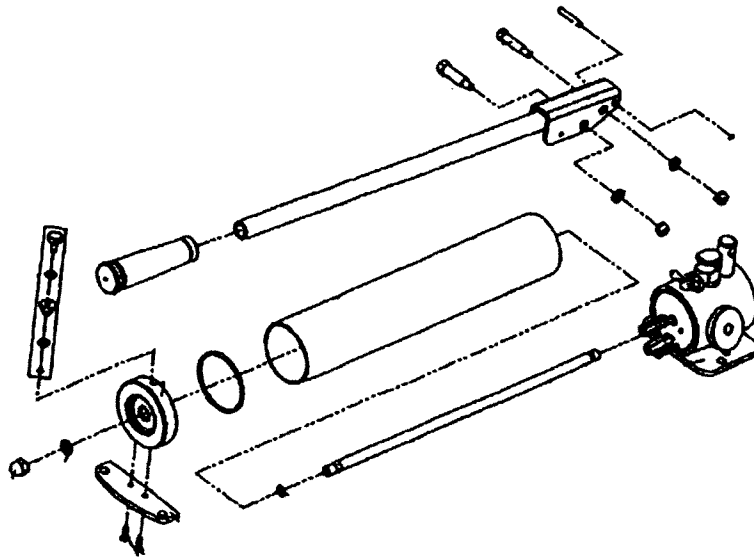

Figure 1

Downloaded From: <https://atikaschool.org>

STATION 2

INSTRUCTIONS

Using the tools, equipment and materials provided, fabricate the aircraft VHF radio compartment tray as shown in Figure 2. (10 marks)

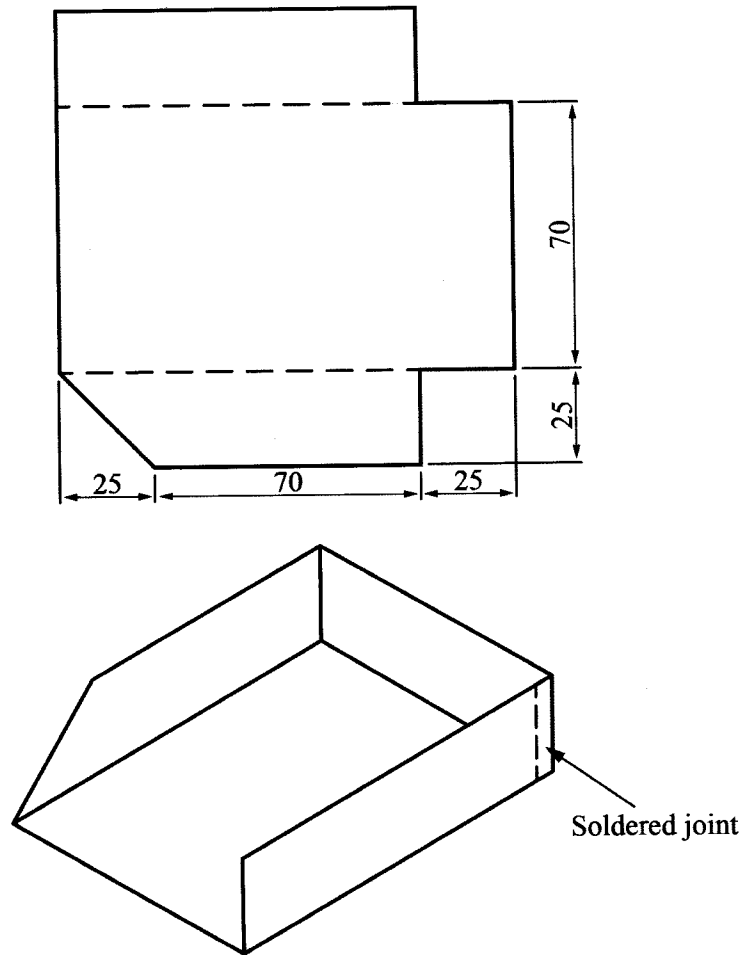

Figure 2

STATION 3

INSTRUCTIONS

Using the multimeter and assembly 'K' provided, perform the following tasks: (1 mark)

- (a) (i) Set the multimeter to AC – 220–250 volts.
- (ii) Plug assembly 'K' to the power source. Let the examiner check your work.
- (b) Select the main source and component 'A' to 'On' position. Measure and record the voltage across: (1 mark)

- (i) T_1 and T_2
Voltage

- (ii) T_1 and T_6
Voltage

Switch of component A.

- (c) Connect terminals T_5 and T_4 to points 1 and 2 respectively on component 'C'. (3 marks)

- (i) Measure and record voltage across terminal T_2 and point 2.
Voltage

- (ii) Select component 'A' to On position. Record the observations.
Observations
-

- (iii) Switch 'off' component 'A'. Replace terminal T_5 with T_6 . Select component 'A' to 'On' position and record the observations.
Observations
-

- (iv) Measure and record voltage across terminal T_1 and T_6 .
Voltage

- (v) Select component 'A' to off position. Disconnect terminals T_4 and T_6 from points 1 and 2 on component 'C'. Let the examiner check your work.

Downloaded From: <https://atikaschool.org>

(d) State:

(3 marks)

(i) The reasons for the observations in c(i), (ii) and c(iii).

Reasons

.....

(ii) Two systems where the sytem is applicable on an aircraft electrical system.

Systems 1.

2.

(e) Identify components A, B, C and D on assembly 'K'.

(2 marks)

Components A

B

C

D

Downloaded From: <https://atikaschool.org>

STATION 4

INSTRUCTIONS

Using part labelled 'E' and the precision tools provided, perform the following tasks: (2 marks)

- (a) (i) Identify part 'E'

Identification

- (ii) State the type

Type

- (iii) Give the use:

Use

- (iv) State the importance of taper angle.

Taper angle importance

- (b) Take the measurements and complete **table 1**. (6 marks)

Table 1

ITEM	DESCRIPTION OF MEASUREMENT	MEASUREMENT
(i)	External diameter of outer race.	
(ii)	Width of outer race.	
(iii)	Bore diameter.	
(iv)	Taper Angle.	
(v)	Thickness of the face.	
(v)	Gap between inner and outer race.	

- (c) State **four** rejection criteria for part E criteria. (2 marks)

(i)

(ii)

(iii)

(iv)

STATION 5

INSTRUCTIONS

Using tools and component 'F' provided, perform the following tasks:-

- (a) Study the tool labelled 1 and identify: (2 marks)
- (i) Name of the tool
 - (ii) Use of the tool
 - (iii) Maintenance check required
 - (iv) Type
- (b) Study component 'F' and identify: (1½ marks)
- (i) Component
 - (ii) Type
 - (iii) System applicable
- (c) Dismantle component 'F'.
- (i) Identify parts G, H, J, K and L. (2½ marks)
 - G
 - H
 - J
 - K
 - L
 - (ii) State the use of parts painted white and blue. (1 mark)
 - White
 - Blue

Downloaded From: <https://aikaschool.org>

- (iii) Examine parts G, J, K and L and identify the maintenance checks for each. (2 marks)

Part G

J

K

L

- (d) Record **two** failure indicators for component 'F' during engine run. (1 mark)

Indicators:

(i)

(ii)

STATION 6

INSTRUCTIONS

Using the tools and instruments labelled M and N, perform the following tasks:-

- (a) Study the instruments 'M' and 'N'. Record the observations. (1 mark)

Observations:

M

N

- (b) Remove the instruments cover. Study the mechanisms and operations of each and answer questions b(i) to b(iv). (8 marks)

- (i) State principle of operation.

M

N

- (ii) Identify operating mechanism

M

N

- (iii) Determine the sensitivity

M

N

(iv) Identify and state the function of four common parts.

Part:	Function:
1.
2.
3.
4.

(v) State the instrument grouping

M

N

(c) State **two** physical checks that should be carried on instruments 'M' and 'N' on the aircraft before flight. (1 mark)

Checks:

- (i)
- (ii)

Downloaded From: <https://stikaschool.org>

STATION 7

INSTRUCTIONS

Using the tools and component P provided, perform the following tasks:-

- (a) Study component 'P' and identify: (2 marks)
- (i) The component
 - (ii) Component type
 - (iii) System where applicable
 - (iv) Type of aircraft where used
- (b) (i) Dismantle the component P. Let the examiner check your work. (1 mark)
- (ii) Identify parts painted white, blue, red and green. (2 marks)
- White
- Blue
- Red
- Green
- (iii) Identify **four** defects on component 'P' (2 marks)
- Defects:
- (iv) Assemble component 'P'. Let the examiner check your work. (1 mark)
- (c) Give **four** routine checks to be carried on component P. (2 marks)
- Routine checks:

Downloaded From: <https://latikaschool.org>

STATION 8

INSTRUCTIONS

Using the material labelled 'Q' and hardware labelled 'R', perform the following tasks:-

(a) Study the structure of material 'Q' and answer question a(i) to a(iii). (4 marks)

(i) Identify the material.

Material

(ii) State the reason for use in aircraft construction.

Reason

(iii) Sketch and label the cross section through the material in the space below.

(b) Study hardware 'R' and answer questions b(i) to b(iii). (6 marks)

(i) Identify the hardware.

Hardware

(ii) State the condition of the hardware.

Condition

(iii) Sketch and label the external thread profile in the space below.

Downloaded From: <https://aikaschool.org>

STATION 9

INSTRUCTIONS

Using the airport model labelled 'S', aircraft model call sign N123QZ labelled T and tower instructions as shown in table 2, perform the following tasks.

- (a) Demonstrate and explain to the examiner the procedure of taxiing call sign N123QZ from apron to scenarios, A, B, C and D. (8 marks)

TABLE 2

Scenario	Tower Instructions
A	NOVEMBER 123QZ Runway 16, taxi via Alpha
B	NOVEMBER 123QZ Runway 24, taxi via Alpha 2, Charlie and Bravo. Hold short runway 34.
C	NOVEMBER 123QZ Runway 34, taxi via Alpha.
D	NOVEMBER, 123QZ, line up and wait Runway 6, via Alpha and Bravo cross runway 6

- (b) List **four** facilities at the airport which guide the aircraft pilot during taxiing. (2 marks)

Facilities

1.
2.
3.
4.

Downloaded From: <https://atikaschool.org>

STATION 10

INSTRUCTIONS

Using the materials and tools provided, perform the following tasks:

- (a) Weigh parts labelled 'U' and 'V' and record the weight. (2 marks)

Part 'U'

Part 'V'

- (b) (i) Fill beaker labelled 'N' with water. Position the beaker on top of a stool. Set the graduated cylinder labelled 'X' at the spout of the beaker. Immerse part 'U' to the beaker 'W'. Take and record the volume of water displaced by part U. (1 mark)

Volume

- (ii) Repeat b(i) and with part 'V'. Take and record the volume of water displaced by part 'V'. (1 mark)

Volume

- (c) (i) Relate observations in a(i) and a(ii). (2½ marks)

Relationship

.....

- (ii) Relate observations in b(i) and b(ii).

Relationship

.....

- (iii) State the principle from the observations in a(i) (ii) and b(i), (ii)

Principle

- (iv) State **two** applications of the principle in theory of flight.

Applications 1.

2.

- (d) Determine the lift of aircraft model labeled Z flying at 500kph at sea level if the lift co-efficient is 0.87. (3½ marks)

Downloaded From: <http://aikaachool.org>