

Name..... Index No...../.....

233/2
CHEMISTRY
Paper 2
(THEORY)
Oct./Nov. 2015
2 hours

Candidate's Signature.....

Date.....



THE KENYA NATIONAL EXAMINATIONS COUNCIL
Kenya Certificate of Secondary Education
CHEMISTRY
Paper 2
(THEORY)
2 hours



02325210

Instructions to candidates

- (a) Write your name and index number in the spaces provided above.
- (b) Sign and write the date of examination in the spaces provided above.
- (c) Answer **all** the questions in the spaces provided.
- (d) KNEC Mathematical tables and silent electronic calculators may be used.
- (e) All working **must** be clearly shown where necessary.
- (f) **This paper consists of 13 printed pages.**
- (g) **Candidates should check the question paper to ascertain that all the pages are printed as indicated and that no questions are missing.**
- (h) **Candidates should answer the questions in English.**

For Examiner's Use Only

Questions	Maximum Score	Candidate's Score
1	11	
2	12	
3	13	
4	11	
5	10	
6	12	
7	11	
Total Score	80	



- 1 (a) (i) Carbon (IV) oxide is present in soft drinks. State **two** roles of carbon (IV) oxide in soft drinks. (1 mark)

.....

.....

.....

- (ii) Explain the observation made when a bottle containing a soft drink is opened. (2 marks)

.....

.....

.....

.....

- (iii) Carbon (IV) oxide dissolves slightly in water to give an acidic solution. Give the formula of the acid. (1 mark)

.....

- (b) Zinc oxide can be obtained by heating zinc nitrate. A student heated **5.76 g** of zinc nitrate.

- (i) Write an equation for the reaction that occurred. (1 mark)

.....

.....

- (ii) Calculate the total volume of gases produced. (Molar gas volume is 24 dm^3 ; Zn = 65.4; O = 16.0; N = 14.0). (4 marks)

.....

.....

.....

.....

- (iii) Identify the element that is reduced when zinc nitrate is heated. Give a reason. (2 marks)

.....
.....

- 2 (a) Draw the structure of the following compounds. (2 marks)

- (i) Butanoic acid;

.....
.....
.....

- (ii) Pent-2-ene.

.....
.....
.....

- (b) Explain why propan-1-ol is soluble in water while prop-1-ene is not. (Relative molecular mass of propan-1-ol is 60 while that of prop-1-ene is 42). (2 marks)

.....
.....
.....
.....

- (c) What would be observed if a few drops of acidified potassium manganate (VII) were added to oil obtained from nut seeds? Explain. (2 marks)

.....
.....
.....
.....

- (d) State **one** method that can be used to convert liquid oil from nut seeds into solid. (1 mark)
-

- (e) Describe how soap is manufactured from liquid oil from nut seeds. (3 marks)
-
-
-
-
-
-

- (f) 0.44 g of an ester **A** reacts with 62.5 cm³ of 0.08 M potassium hydroxide giving an alcohol **B** and substance **C**. Given that one mole of the ester reacts with one mole of the alkali, calculate the relative molecular mass of the ester. (2 marks)
-
-
-

- 3 (a) Name the method that can be used to obtain pure iron (III) chloride from a mixture of iron (III) chloride and sodium chloride. (1 mark)
-

- (b) A student was provided with a mixture of sunflower flour, common salt and a red dye. The characteristics of the three substances in the mixture are given in the table below.

Substance	Solubility in water	Solubility in ethanol
Sunflower flour	Insoluble	Insoluble
Common salt	Soluble	Insoluble
Solid red dye	Soluble	Soluble

The student was provided with ethanol and any other materials needed.
Describe how the student can separate the mixture into its three components.

(3 marks)

.....

.....

.....

.....

.....

.....

- (c) The diagram below shows part of a periodic table. The letters do not represent the actual symbols of elements. Use the diagram to answer the questions that follow.

									Q
R					T				
			N		V			W	
Y								X	

- (i) Explain why the oxidising power of W is more than that of X. (2 marks)

.....

.....

.....

- (ii) How do the melting points of R and T compare? Explain. (2 marks)

.....

.....

.....

(iii) Select an element that could be used:

(I) in weather balloons; (1 mark)

.....

(II) for making a cooking pot. (1 mark)

.....

(d) (i) Classify the substances **water, iodine, diamond** and **candle wax** into elements and compounds. (2 marks)

Elements	Compounds

(ii) Give **one** use of diamond. (1 mark)

.....

.....

4 (a) The diagram below represents a dry cell. Use it to answer the questions that follow.

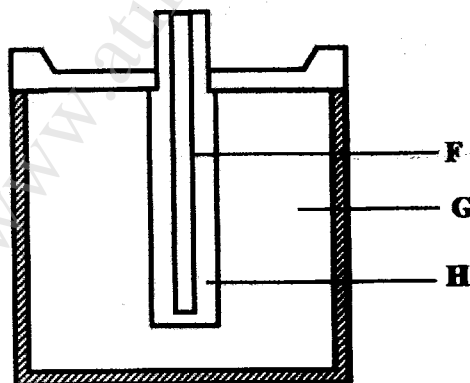

(i) Which of the letters represent:

(I) carbon electrode?

(1 mark)

(II) the electrolyte?

(1 mark)

(ii) One of the substances used in a dry cell is manganese (IV) oxide. State **two** roles of manganese (IV) oxide in the dry cell. (2 marks)

(b) Below is a simplified electrolytic cell used for purification of copper. Study it and answer the questions that follow.

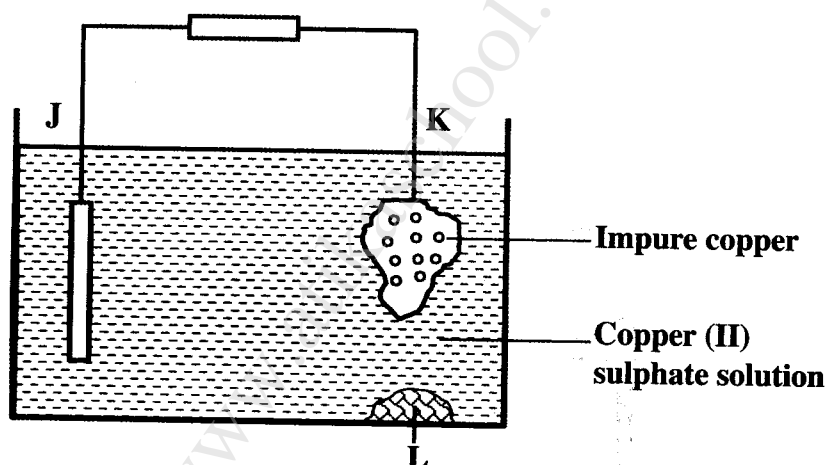

(i) Identify the cathode.

(1 mark)

(ii) Write the equation for the reaction at the anode.

(1 mark)

(iii) What name is given to L? (1 mark)

.....

(iv) A current of 0.6 A was passed through the electrolyte for 2 hours. Determine the amount of copper deposited.
(Cu = 63.5; 1 Faraday = 96,500 coulombs). (3 marks)

.....

.....

.....

.....

(v) State two uses of copper metal. (1 mark)

.....

.....

5 The set-up below can be used to generate a gas without heating. This occurs when substance M reacts with solid N.

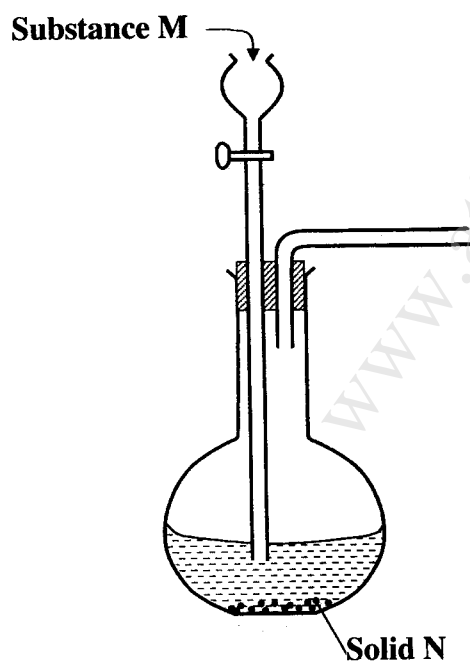

Kenya Certificate of Secondary Education, 2015
233/2
02325210

- (a) (i) Complete the table below giving the names of substance M and solid N if the gasses generated are chlorine and sulphur (IV) oxide. (2 marks)

	Chlorine	Sulphur (IV) oxide
Substance M		
Solid N		

- (ii) Complete the diagram above to show how a dry sample of sulphur (IV) oxide can be collected. (3 marks)

- (b) Describe **two** chemical methods that can be used to test the presence of sulphur (IV) oxide. (3 marks)

.....

.....

.....

.....

.....

.....

- (c) Other than the manufacture of sulphuric (VI) acid, state **two** uses of sulphur (IV) oxide. (2 marks)

.....

.....

- 6 (a) Other than concentration, state **two** factors that determine the rate of a reaction. (2 marks)

.....

.....

.....

- (b) In an experiment to determine the rate of reaction, excess lumps of calcium carbonate were added to 2 M hydrochloric acid. The mass of calcium carbonate left was recorded after every 30 seconds. The results are shown in the table below.

Time (seconds)	0	30	60	90	120	150	180	210
Mass of calcium carbonate left (g)	2.00	1.60	1.30	1.00	0.85	0.8	0.8	0.8

- (i) Write the equation for the reaction that took place. (1 mark)

.....

.....

- (ii) On the grid provided, plot a graph of mass of calcium carbonate vertical axis against time. (3 marks)

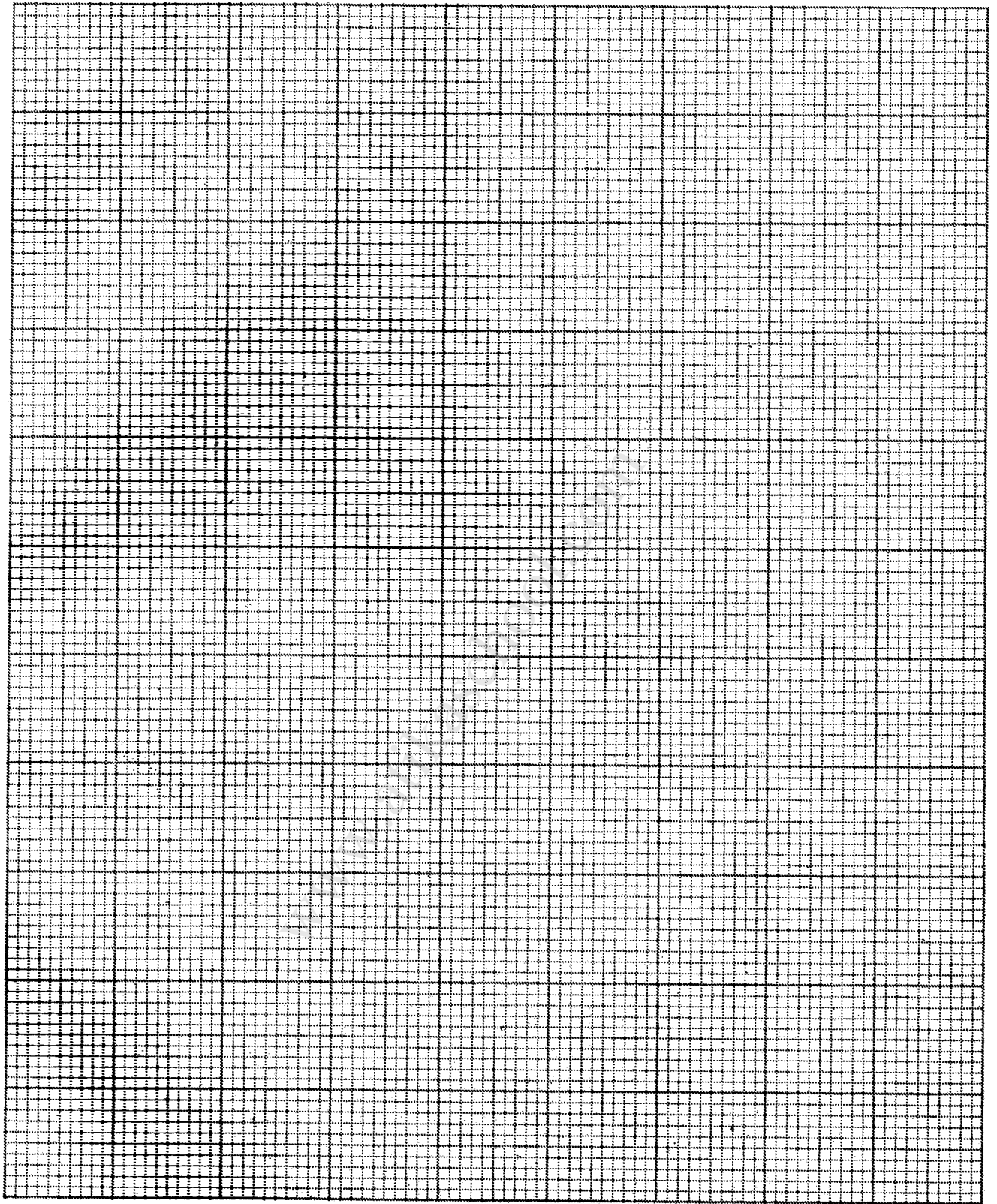

Kenya Certificate of Secondary Education, 2015
233/2
02325210

915033

Turn over

- (iii) Determine the rate of reaction at the 105th second. (3 marks)

.....

.....

.....

.....

- (c) Why does the curve level off after some time? (1 mark)

.....

.....

- (d) On the same grid, sketch a curve for the same reaction using 4 M hydrochloric acid and label the curve R. (2 marks)

- 7 (a) Naturally occurring magnesium consists of three isotopes. 78.6% ²⁴Mg; 10% ²⁵Mg and ²⁶Mg. Calculate to one decimal place, the relative atomic mass of magnesium. (2 marks)

.....

.....

.....

- (b) When magnesium burns in air, it forms a white solid and a grey-green solid. When a few drops of water are added to the mixture, a gas that turns red litmus paper blue is evolved.

Identify the:

- (i) white solid. (1 mark)

.....

- (ii) gas evolved and state its use.

- (I) Name of gas. (1 mark)

.....

- (II) Use of the gas. (1 mark)

.....

Kenya Certificate of Secondary Education, 2015

233/2

02325210

- (c) Two different samples of water (I and II) were tested with soap solution. Sample II was further subjected to two other processes before adding soap. 20 cm³ of each sample of water was shaken with soap solution in a boiling tube until a permanent lather was obtained. The results are shown in the table below.

Water sample	Volume of soap solution needed (cm ³)	
	before boiling	after boiling
I	10	5
II	6	6
II after filtering	6	6
II after distilling	2	2

- (i) Identify the water sample that had temporary hardness. Explain your answer. (2 marks)

.....

.....

.....

- (ii) Explain why the results for sample II are different after distilling but remain unchanged after filtering. (2 marks)

.....

.....

.....

.....

.....

- (iii) State two disadvantages of using both water samples for domestic purposes. (2 marks)

.....

.....

THIS IS THE LAST PRINTED PAGE.

Kenya Certificate of Secondary Education, 2015

233/2

02325210