

NAME.....INDEX NUMBER.....

CLASS.....CANDIDATE'S SIGNATURE..... DATE.....

233/2

CHEMISTRY

THEORY

Paper 2

Time: 2 Hours

December 2021

BUNAMFAN CLUSTER EXAMINATION 2021

233/2

CHEMISTRY

THEORY

Paper 2

Time: 2 Hours

December 2021

INSTRUCTIONS TO CANDIDATES

- Write your **name** and **index number** in the spaces provided.
- Sign and write the date of the examination in the spaces provided above.
- Answer **all** the questions in the spaces provided.
- Mathematical tables and silent electronic calculators may be used.
- All **working must be clearly shown** where necessary.
- This paper **consists of 13 printed pages**.

FOR EXAMINERS USE ONLY

Questions	Maximum Score	Candidate's Score
1	11	
2	14	
3	12	
4	11	
5	12	
6	10	
7	10	
TOTAL	80	

1. The diagram below shows an experiment to demonstrate the properties of hydrogen as a reducing agent. Study it and answer the questions that follow.

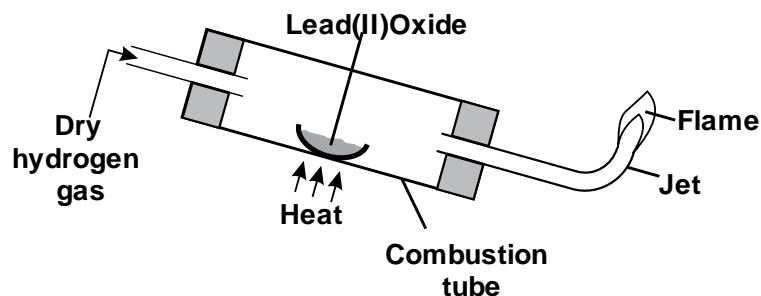

- a) Before lighting hydrogen gas at the jet, it is important to drive off all the air in the combustion tube. Explain. (1 mark)

.....

- b) State what would be observed in the boat containing lead (II) oxide at the end of the experiment. (1 mark)

.....

- c) Write chemical equations for the reaction taking place;
i) In the combustion tube. (1 mark)

- ii) At the jet as the flame burns. (1 mark)

.....

- d) Why should the supply of hydrogen continue until the apparatus are cool? (1 mark)

.....

- e) Why is it important to clamp the glass tube or combustion tube in a slanting position? (1 mark)

.....

- f) i) Cars in Mombasa rust faster than in Kisumu. Explain. (1 mark)

.....

.....

- ii) Give the factors that are necessary for rusting. (1 mark)

.....

iii) Name **two** methods used to prevent rusting. (1 mark)

.....
.....

iv) Explain why a nail placed in a sealed tube containing tap water rusts while a nail placed in a sealed tube containing boiled water fails to rust. (1 mark)

.....
.....

v) State **two** industrial uses of oxygen gas. (1 mark)

.....
.....

2. The grid shown below represents part of the periodic table. Study it and answer the question that follow. The letters do not represent the actual symbol of the elements.

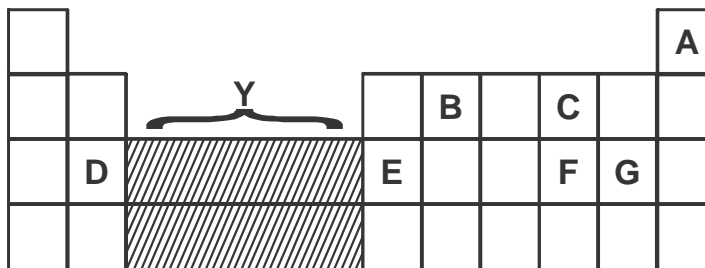

a) What type of bonds would be formed between C and G. Explain. (2 marks)

.....
.....
.....

b) Write the formulae of the compounds that would be formed between:
i) D and G (1 mark)

.....

ii) E and G (1 mark)

.....

c) State and explain how the compounds formed in (b) above compare in their melting points in terms of structure and bonding. (2 marks)

.....
.....
.....

d) Give the formulae of the oxides of the elements D and F and state the nature of each oxide.

i) D oxide (2 marks)

Formulae

Nature

ii) F oxide (2 marks)

Formulae

Nature

e) Which of the elements shown does not form an oxide? Explain. (1 mark)

.....
.....

f) Which two elements shown on the grid are good conductors of electricity? Explain. (2 marks)

.....
.....

g) What name is given to the group of elements represented by letter Y in the periodic table? (1 mark)

.....

3. (a) Brine usually contains soluble calcium and magnesium salts. Explain how sodium carbonate is used to purify brine. (2 marks)

.....
.....
.....
.....

The diagram below represents a diaphragm cell used to electrolyse pure brine

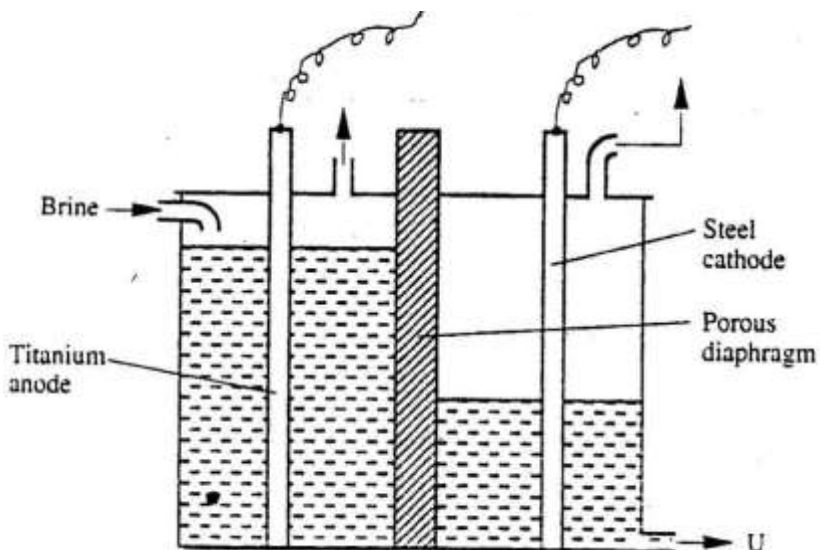

(a) Write the equations for the reactions that take place at :-
 I Cathode (1 mark)

.....

II Anode (1 mark)

.....

(b) Name: I Product at U. (1 mark)

.....

II Another material that can be used instead of titanium (1 mark)

.....

III The impurity present in the product at U (1 mark)

.....

IV State **two** functions of the diaphragm (2 marks)

.....

c) Give **one** industrial use of the product at U. (1 mark)

.....
.....

d) State **two** environmental hazards associated with extraction of sodium metal (2 marks)

.....
.....
.....

4. The diagram below illustrates the contact process for the manufacture of sulphuric (VI) acid. Study it and answer the questions that follow.

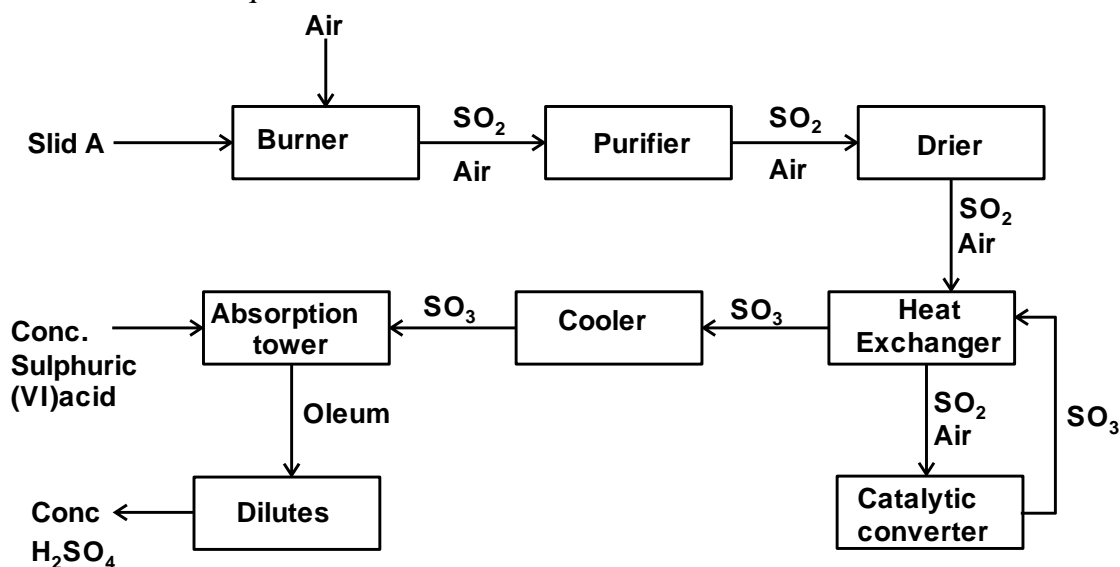

a) Name **three** possible identities of solid A. (1½ marks)

.....
.....
.....

b) i) Name **two** impurities removed by the purifier. (1 mark)

.....
.....

ii) Why is it necessary to remove the impurities? (1 mark)

.....

c) Write down the equation for the reaction that takes place in the catalytic converter. (1 mark)

.....

d) i) Name **two** catalysts that can be used in the converter. (2 marks)

.....

.....

ii) Which of the **two** catalysts is most commonly used and why? (1 mark)

.....

.....

e) Why is sulphur (VI) oxide not absorbed directly into water? (1 mark)

.....

f) Give the equation for the reaction that takes place in the absorption chamber. (1 mark)

.....

g) Name the main pollutant in the contact process. (½ mark)

.....

h) Name **one** method by which the pollution is controlled in the contact process. (1 mark)

.....

5. Study the table below and answer the questions that follow;

Reduction Half-reaction E⁰(Volts)

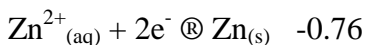

a) Which is the strongest reducing agent in the above half equations? Explain. (2 marks)

.....

.....

b) Calculate the electromotive force of a cell consisting of Zinc and silver electrodes immersed in solutions of their respective ions. (2 marks)

.....

.....

.....

c) Give the cell representation of the cell in (b) above. (1 mark)

.....

.....

d) The diagram below represents an experiment set up used for the electrolysis of aqueous copper (II) sulphate solution. Study it and answer the questions that follow;

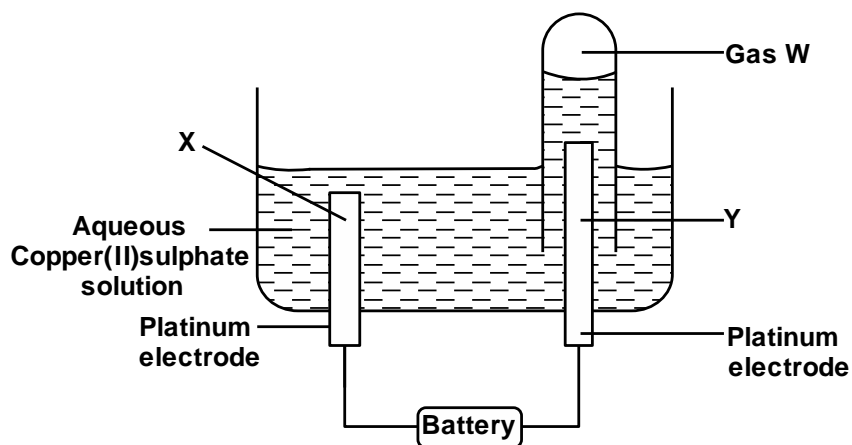

i) Name electrodes X and Y. (2 marks)

.....

.....

ii) Name gas W. (1 mark)

iii) Write the overall equation of the reactions taking place at electrodes X and Y. (1 mark)

.....

iv) If a current of 0.4A was passed through the cell for 15 minutes, calculate the mass of copper that would be liberated. (Relative atomic mass of copper = 64, $1F = 96,500C$) (3 marks)

.....

.....

.....

.....

.....

6. The scheme below shows a series of reactions starting with ethanol. Study it and answer the questions that follow.

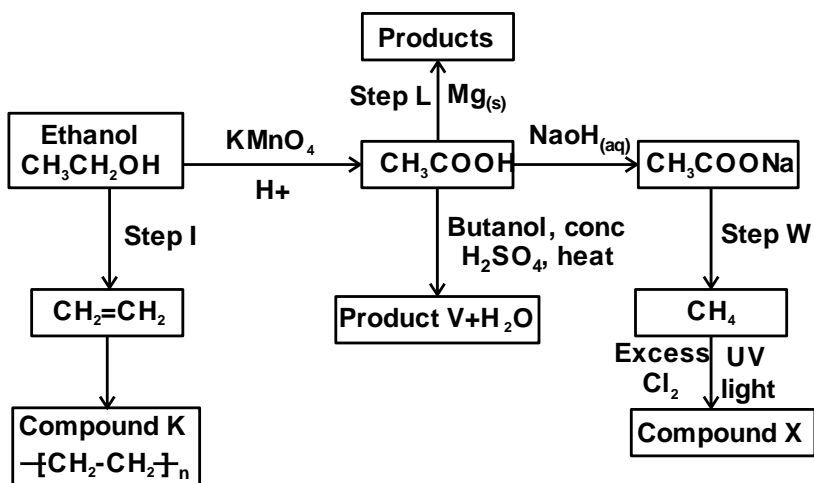

a) Give the type of reaction, the reagent(s) and the condition(s) necessary for step 1 to take place. (1 mark)

.....

b) Write the equation for the reaction that takes place in step L. (1 mark)

.....

c) Name product V and give the equation responsible for its formation. (2 marks)

.....

.....

d) Give the reagent(s) and condition(s) necessary for step W to take place. (1 mark)

.....

.....

e) Give the IUPAC name and structural formula of compound X. (1 mark)

.....

f) Name compound K and state the type of reaction involved in its formation. (2 marks)

.....

.....

g) If the relative molecular mass of K is 44800, determine the value of n. ($C = 12, H = 1$) (2 marks)

.....

.....

.....

7. The set up below is used to measure the change in mass during the course of the reaction between dilute hydrochloric acid (excess) and marble chips at 22°C.

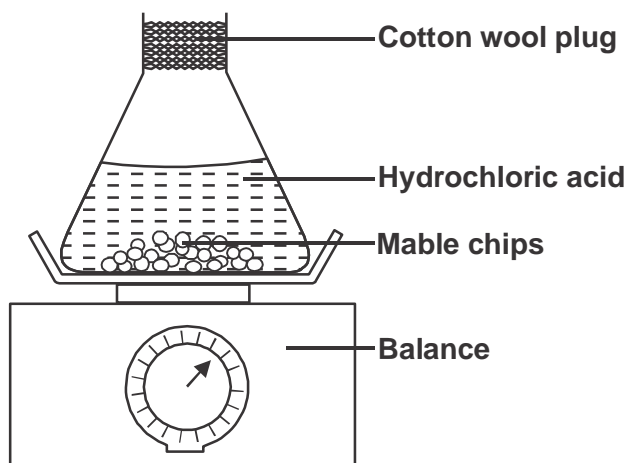

Changes in mass were noted at one minute intervals and were as follows.

a) Give an equation for the reaction taking place in the flask. (1 mark)

.....

b) Why did the mass of the flask change with time? (1 mark)

.....

c) What is the role of cotton wool at the mouth of the flask? (1 mark)

.....

d) Plot a graph of loss in mass (Y-axis) against time (X-axis). Label the curve 22°C. (3 marks)

Time (min)	1	2	3	4	5	6	7
Loss in mass(g)	0.26	0.46	0.60	0.69	0.73	0.73	0.73

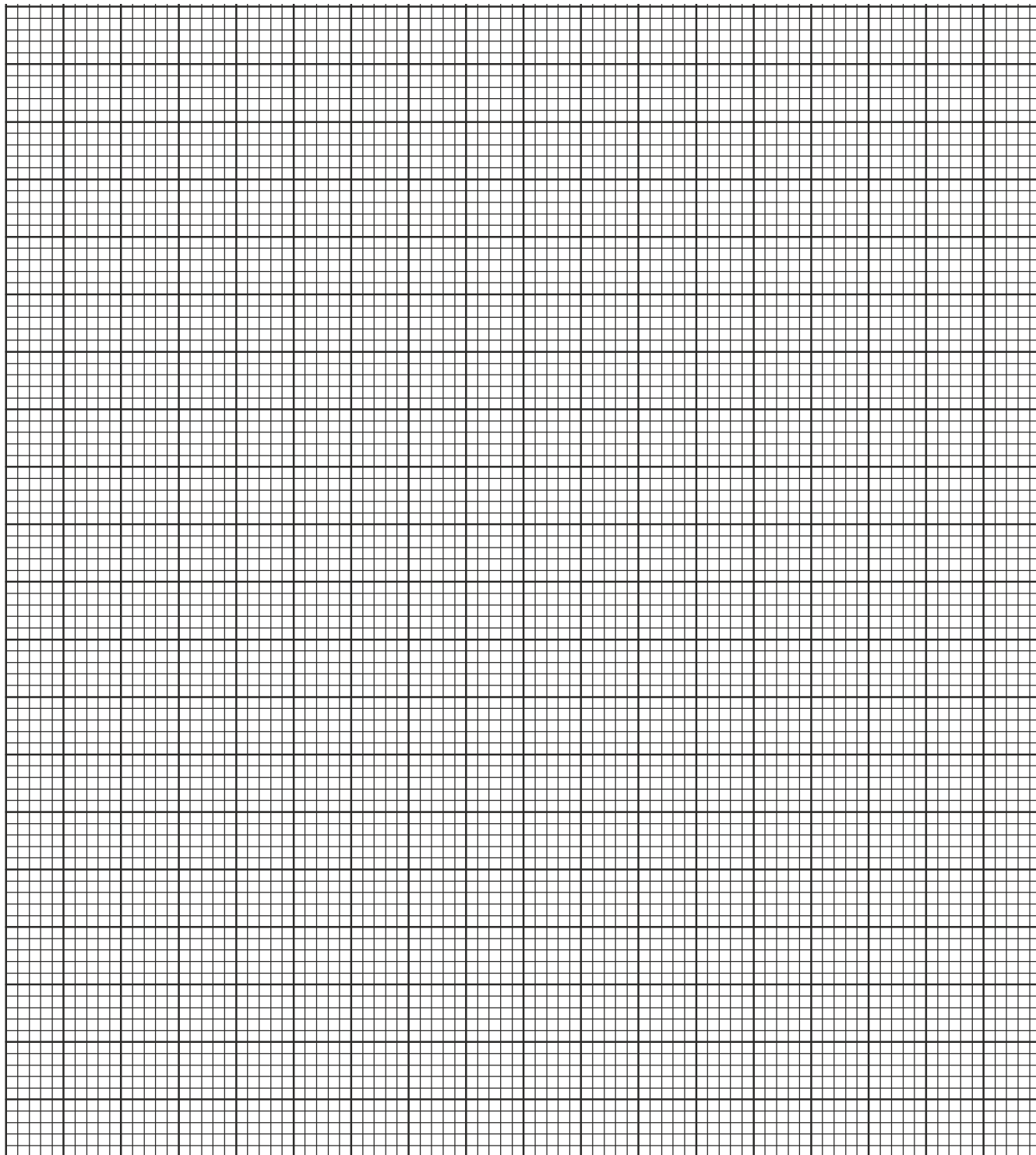

e) On the graph same axis as in (d) above, sketch the graph you would expect to obtain if the experiment was repeated at 35°C. Label the curve 35°C. (2 marks)

f) State what would happen if the marble chips were replaced with the same mass of marble powder. Explain (2 marks)

.....
.....

g) Why is it not advisable to use sulphuric (VI) acid in place of hydrochloric acid in this experiment? (1 mark)

.....
.....