

GATITU SECONDARY SCHOOL

FORM 2 GEOGRAPHY MIDTERM TERM 1 2016

ANSWER ALL QUESTIONS IN THIS PAPER

a) Name two types of earth movements

.....
.....

b) List down 4 causes of earth movements(4mks)

.....
.....
.....
.....

c) State the continental drift theory(1mk)

.....
.....
.....

d) LIST down 8 evidences that support the continental drift theory(8mks)

.....
.....
.....
.....
.....
.....
.....
.....

e) Explain any 2 methods mentioned above(4mks)

.....
.....
.....
.....

.....
.....
.....
.....

f) Mention the 3 types of tectonic boundaries(3mks)

.....
.....
.....

g) Mention a features associated with each boundary mentioned in(f) above(3mks)

.....
.....
.....

2(a) Define the term folding(1mk)

.....
.....
.....

b) List down seven types of folds(7mks)

.....
.....
.....
.....
.....
.....

(c) The diagram below represent a fold.

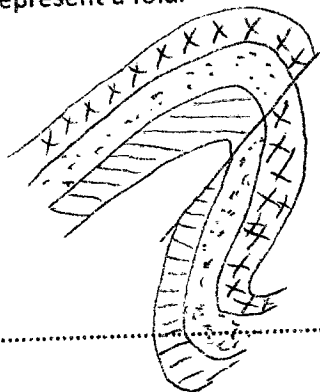

name it.....(1mk)

(d)(i)Mention six features that result from folding(6mks)

.....
.....
.....
.....
.....
.....
.....

(ii)Mention three theories put forward to explain formation of fold mountains(3mks)

.....
.....
.....

(e)What is orogenesis?(1mk).Name 4 orogenies(4mks)

.....
.....

(f)Explain any six significance of folding to human activities.(6mks)

.....
.....
.....
.....
.....
.....
.....
.....
.....
.....
.....
.....

3(a)Define the term faulting.(1mk)

.....
.....
.....

(b)The diagram below represent a normal fault.Label the parts marked (i) to(viii).(8mks)

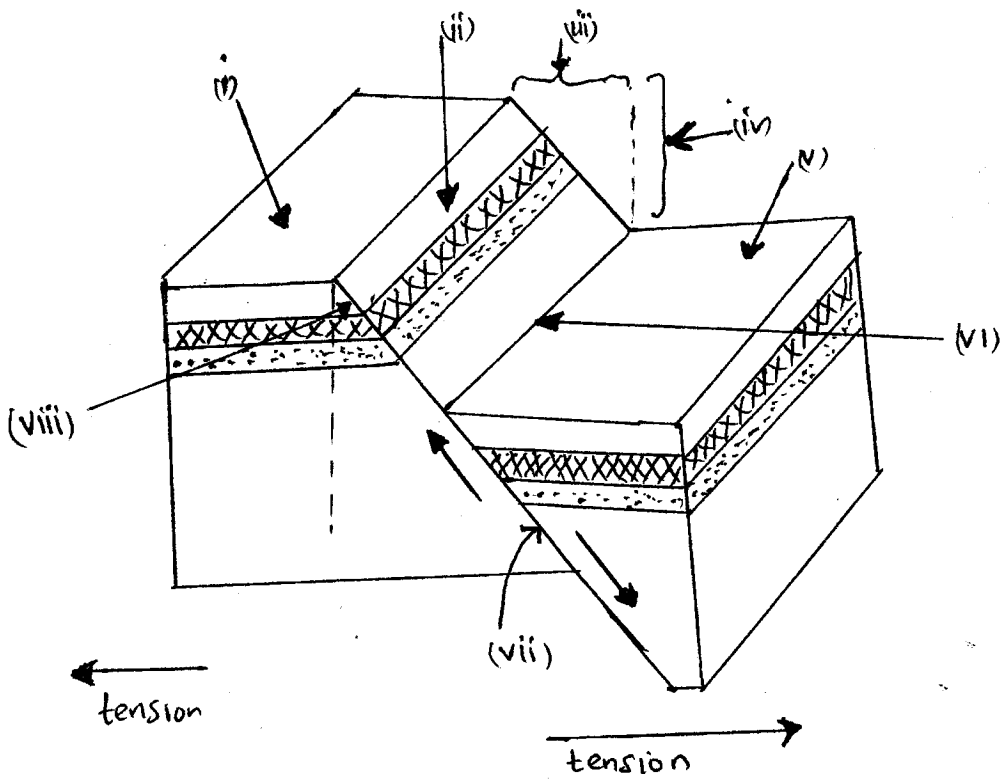

(c) Apart from normal fault mention any other 4 types of faults. (4mks).

.....

.....

.....

.....

(d) Name 4 features that result from faulting. (4mks)

.....

.....

.....

.....

END