

312/2
GEOGRAPHY
PAPER 2
OCTOBER 2016
2¾ HRS

KANDARA SUB-COUNTY SECONDARY SCHOOLS FORM 3 2016
JOINT EXAMINATION
Kenya Certificate of Secondary Education (KCSE)

GEOGRAPHY
Paper 2
October 2016
Time: 2¾ hours

INSTRUCTIONS TO CANDIDATES

- a) This paper has **two** sections **A** and **B**.
- b) Answer **All** questions in section **A**.
- c) Answer **questions 6** and any other **two** questions in section **B**.

SECTION A

1. a) What is agroforestry? (2 marks)
b) State three reasons why agroforestry is being encouraged in Kenya. (3 marks)

2. a) Define
i) Livestock ranching (1 mark)
ii) Transhumance (1 mark)
b) Give three types of exotic beef breeds in Kenya. (3 marks)

3. a) Name the minerals found in the following areas in Kenya.
i) Kariandusi (1 mark)
ii) Kerio valley (1 mark)

b) State three effects of open-cast mining on the environment. (3 marks)

4. a) State three physical conditions that are necessary for the growing of cocoa. (3 marks)
b) Give two economic problems experienced in cocoa farming in Ghana. (2 marks)

5. a) What is arable farming? (2 marks)
b) State three characteristics of shifting cultivation. (3 marks)

SECTION B

Answer question 6 and any other two questions from this section.

6. Study the table below and answer the questions that follow.

Amount in '000' kilograms in five years					
Crop/Year	2010	2011	2012	2013	2014
Coffee	1000	990	870	850	840
Tea	750	700	650	700	600
Pyrethrum	300	250	350	400	450
Cotton	500	450	550	600	350

- a) i) Using a scale of 1cm represents 200,000kg represent the data on a compound bar graph. (9 marks)
ii) List two advantages of using a compound bar graph to present statistical data. (2 marks)

- b) Students from Kiangare Secondary in Kandara Sub-county went to study tea growing in Kigumo Tea Estate.
 - i) State any two preparations made before the field study. (2 marks)
 - ii) Give any two follow-up activities the students are likely to engage in after the study. (2 marks)
 - iii) Identify three physical factors that favour tea growing in Kigumo Tea Estate that the students might have found. (3 marks)

- c) i) State three problems that the students are likely to have encountered during their field study. (3 marks)
- ii) Give three ways in which the student's would have presented their findings from the study in (b) above. (3 marks)
7. a) i) Differentiate between forest and forestry. (2 marks)
- ii) Give two examples of soft wood trees found in Kenya. (2 marks)
- b) Give importance of forests in Kenya. (5 marks)
- c) i) Explain how the following factors influence the distribution of natural forests. (6 marks)
- i) Temperature
- ii) Attitude
- iii) Human activities
- ii) Explain three problems that affects forestry in Canada. (6 marks)
- d) Give four measures being taken to conserve forest in Kenya. (4 marks)
8. a) i) Name two breeds of dairy cattle reared in Kenya. (2 marks)
- ii) State three factors which favour dairy farming in Denmark. (3 marks)
- b) Explain four ways in which the government of Kenya assist nomadic pastoralists to improve the quality of their livestock. (8 marks)
- c) Discuss nomadic pastoralism in Kenya under the following:
- i) The cattle breeds kept (2 marks)
- ii) The pattern of movement (3 marks)
- iii) Marketing of the animals (3 marks)
- d) Give four reasons why nomadic pastoralists keep large herds of animals. (4 marks)

9. a) i) What is derelict land? (1 mark)
 ii) List four ways in which mining affect the environment. (4 marks)

b) The diagram below shows a method of mining.

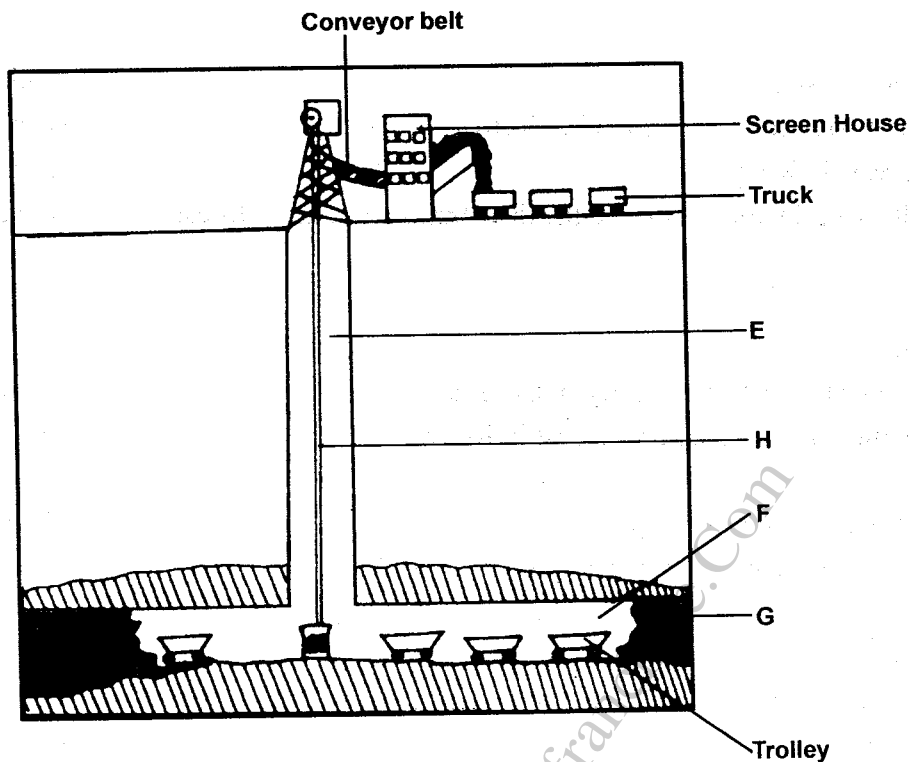

- i) Identify the method of mining shown in the diagram. (2 marks)
 ii) Name the parts marked E, F, G and H. (4 marks)
 iii) Explain three problems associated with the method of mining shown in the diagram. (6 marks)

c) Explain four ways in which gold has contributed to the economy of South Africa. (8 marks)

10. a) i) Name two counties in Kenya where wheat is grown on commercial scale. (2 marks)
 ii) Name two wheat-producing provinces in Canada. (2 marks)
 b) i) Explain three physical conditions that favour wheat growing in Kenya and Canada. (6 marks)
 ii) Explain the factors which enable Canada to produce more wheat than Kenya. (6 marks)
 c) i) Describe the stages involved in cultivation of wheat in Kenya. (3 marks)
 ii) Compare the marketing of wheat in Kenya and Canada. (6 marks)