

GATITU DAY MIXED SECONDARY SCHOOL
MATHEMATICS FORM 1

END OF TERM 2 2012 EVALUATION TEST

Evaluate $\frac{1}{2}$ of $\frac{1}{4} \div \frac{1}{8} + \frac{3}{8} - \frac{1}{8}$ (3mks)

Evaluate $-5 \frac{(23 + 41 - 85)}{40 - 75}$ (3mks)

3. Factorise $3px - py + 3qx - qy$ (3mks)

4. Juma, Ali and Hassan share the profit of their business in the ratio 3:7:9 respectively. If Juma receives sh. 60,000, how much profit did the business yield? (3mks)

5. A man hired a car for two weeks for sh. 10,500. How much would it have cost him to hire it for nine days? (2mks)

6. A farmer has 3 containers of capacity 12 l, 15 l and 21 l. calculate the capacity of
a) the smallest container which can be filled by each one of them an exact number of times.

b) the largest container which fill each one of them an exact number of times. (6mks)

7. solve for x (3mks)

$$\frac{x+2}{4} - \frac{x+3}{5} = \frac{x+4}{6}$$

8. express in g /m³
89 00 kg /m³ (2mks)

9. express in kg /m³
11. 4 g/cm³ (2mks)

10. Below is a travel timetable for a vehicle operating between towns A and D, seventy km apart

| TOWN | ARRIVAL | DEPARTURE |
|------|----------|-----------|
| A | | 10.10 AM |
| B | 10.30 AM | 10.40 AM |
| C | 11.00 AM | 11.05 AM |
| D | 11.20 AM | |

a) at what time does the vehicle depart from town A.

b) how long does it take to travel from town A to town B?

c) for how long does it stay in town B?

d) at what time does it arrive in town D?

e) what is the average speed for the whole journey? (6mks)

11. A session started at 200 h and lasted 10 hrs. At what time did it end? express your answer in both the 24 hr system and a.m /p.m (3mks)

12. A cylindrical jar of diameter 9 cm and depth 12 cm is full of water. The water is poured into a cylindrical glass of diameter 6 cm. What is the depth of the water in the glass? (3mks)

13. Find the area of the shaded region (4mks)

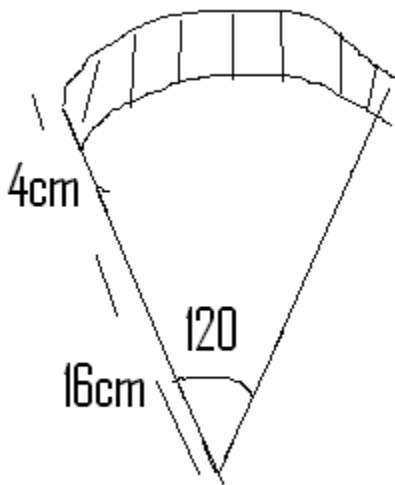

14. Write the value of $2^4 \times 3^2 \times 5^2$ (3mks)

15. Three bells ring at an intervals of 30 min, 35 min and 40 min respectively. If they rang together at 4.10 am in the morning, at what time will they next ring together. (4mks)

16. Express as a fraction 3.256 (3mks)

17. find $\sqrt{15625}$ by factorization (3mks)

18. Add the numbers and express your answer in metres.
0.5 Dm, 30.6 Hm , 120 mm (3mks)

19. An are of a circle subtends an angle 60 at the centre of the circl. Find the length of the arc if the radius of the circle is 42 cm (take $\pi = 22/7$) (3mks)

20. find the ratio a:c if (2mks)
a:b =3:5 b:c = 6:5

21. copy and insert the missing numbers . (3mks)
 $18/90 = \text{---}/30 = 3/\text{---} = \text{---}/5$

22. write in symbols (2mks)
Eighty billion, forty five thousand